



TECHNICAL MANUAL NON-CONTACT DISPLACEMENT TRANSDUCER TYPE SENSAGAP

Serial No.....

Sensitivity.....

Doc. Ref CD1003T



BS EN ISO 9001
Certificate No. FM13141



Affirmed by Declaration
of Conformity

USA & Canada

RDP Electrosense Inc.
2216 Pottstown Pike
Pottstown, PA 19465
U.S.A.

Tel (610) 469-0850
Fax (610) 469-0852
E-mail info@rdpe.com
www.rdpe.com

All other countries

RDP Electronics Ltd
Grove Street, Heath Town,
Wolverhampton, WV10 0PY
United Kingdom

Tel: +44 (0) 1902 457512
Fax: +44 (0) 1902 452000
E-mail: sales@rdpe.com
www.rdpe.com

Index

| | | |
|------|-------------------------------------|---|
| 1 | INTRODUCTION | 2 |
| 1.1 | Target..... | 2 |
| 1.2 | Target size | 2 |
| 1.3 | Target material | 3 |
| 1.4 | Air Gap..... | 3 |
| 1.5. | Gap measurement | 3 |
| 2.0 | MECHANICAL INSTALLATION | 3 |
| 2.1 | Mechanical Dimensions | 4 |
| 3.0 | ELECTRICAL INSTALLATION | 5 |
| 3.1 | Electrical connections | 5 |
| 3.2 | Electrical Output Loading | 5 |
| 3.3 | Connecting to instrumentation | 5 |
| 4. | DYNAMIC APPLICATIONS | 6 |
| 5. | DUAL TRANSDUCER APPLICATIONS | 6 |
| 6 | SPECIFICATION | 6 |
| 7 | WARRANTY AND SERVICE..... | 8 |

1 INTRODUCTION

Sensagap is a non-contact displacement transducer which uses a capacitive technique to measure the distance from the front ceramic face to the target.

1.1 Target

The SENSAGAP can work with a variety of targets. For optimum operation the target should be metallic and its area should cover the target area marked on the face of the transducer and be parallel to it. For optimum operation, it is recommended that the target be electrically grounded.

1.2 Target size

The target can be any size that is greater than the target area. If, for a special application, a small target is required, then the transducer will still operate but may not fully comply with its specification, e.g. the sensitivity will be reduced.

The minimum target size for the 2.5 and 5.0mm models should cover the 1cm x 1cm square area marked on the face of the transducer. On the 10mm model, the area to be covered by the target is a 1.5cm x 1.5cm square, centred on the marked area on the face of the transducer.

On the 20mm unit, the ideal target size is 50 x 50mm minimum.

Targets that are not flat, e.g. round bar, or do not move parallel to the target area of the transducer, can produce good results. Any reduction in performance will be dependent on the actual application.

1.3 Target material

For best performance, the target should be metallic, but other materials do work very well. For highest sensitivity, etc. the dielectric constant (relative permittivity) of the target material should be high and/or resistivity low. Carbon or carbon filled plastic make good targets.

| MATERIAL | DIALECTRIC CONSTANT |
|-----------------|---------------------|
| Air (at N.T.P.) | 1.000 |
| Steel | >4000 |
| Most Plastics | 3 to 10 |
| Water (pure) | 75 |

Most plastics can be detected, but gap not measurable. Water is the odd one out. A plastic container full of water, or a wet surface on plastic, can be used to obtain a good gap measurement with full sensitivity.

1.4 Air Gap

The space between the transducer and the target should only contain material with a dielectric constant near to unity. This includes air, oil-filled air, humid air, etc. For humid air, the important point is to ensure no condensation - this can happen if the temperature is lowered. A film of water on the face of the transducer will upset the measuring ability because the dielectric constant of water is 75 times greater than air.

1.5. Gap measurement

The output signal is nominally zero to 3.0 volts dc for a change in gap (target to transducer) from minimum gap to maximum gap (see table below). The minimum gap is defined as 5% of the range.

| MODEL/RANGE | MIN GAP | MAX GAP |
|-------------|---------|---------|
| 2.5mm | 0.125mm | 2.625mm |
| 5.0mm | 0.25mm | 5.25mm |
| 10.0mm | 0.5mm | 10.5mm |
| 20.0mm | 1.0mm | 21.0mm |

Gap measurements below 5% of range are not possible. The linearity of the measurement is $\pm 0.5\%$ F.S. (or better), (only over 0 to 18 mm on SG20).

2.0 MECHANICAL INSTALLATION

The Sensagap should be fixed to a flat surface using M3 countersunk head screws through the mounting holes provided. Care should be taken to ensure that nothing can impact the active face of the sensor since it is a ceramic and, if damaged, the unit would be irreparable.

The Sensagap is not sealed against the ingress of water and moisture, in fact, as water is a suitable target material for the Sensagap, any moisture on the front face would be interpreted as a very close target and would certainly introduce error. Excessive water would irreparably damage the sensor.

Similar precautions should be taken with dry debris, which, could also be a suitable and 'visible' target for the Sensagap.

2.1 Mechanical Dimensions

SG1.5 & SG5

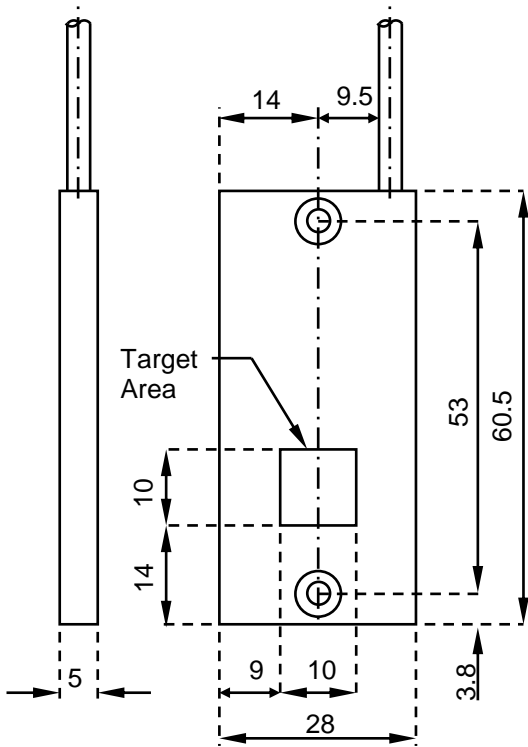

SG10

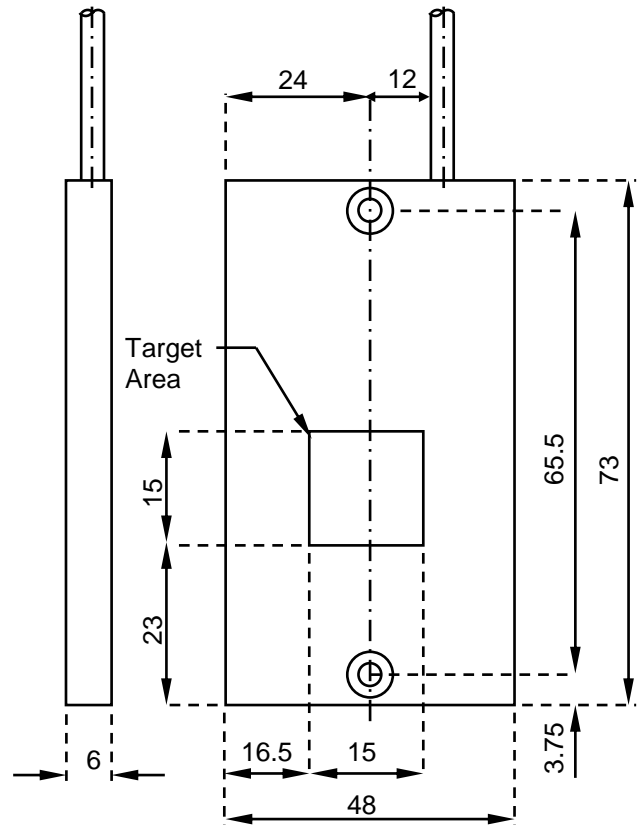

SG20

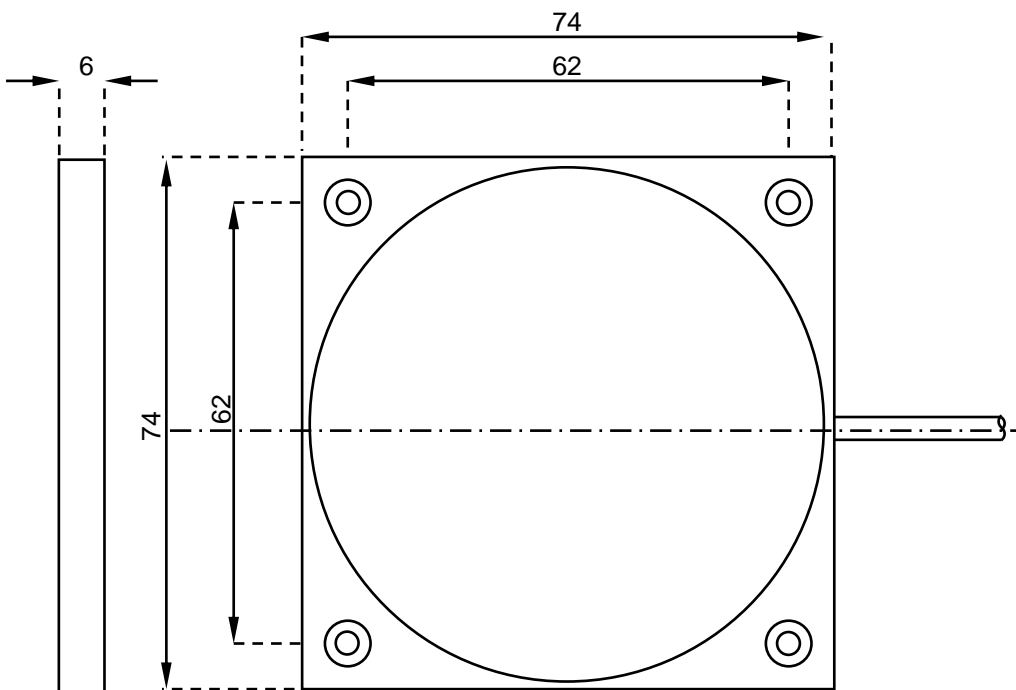

Fixing holes to suit M3 counter-sunk head screw.

All dimensions in mm.

All tolerances ± 0.1 mm

Minimum target size 50mm diameter.

| Model | SG2.5 | SG5 | SG10 | SG20 |
|------------------------------------|-------|-----|------|------|
| Measurement Range (mm) | 2.5 | 5 | 10 | 20 |
| Net weight ,excluding cable. (gms) | 26 | 26 | 42 | 70 |

3.0 ELECTRICAL INSTALLATION

3.1 Electrical connections

The transducer is fitted with a 2m long, four-core screen cable. the connections required are:-

The cable screen (shield) is connected to the body of the transducer and, like the target, should be connected to the ground.

| Core Colour | Connect to: |
|-----------------|---------------------------|
| Red | Positive Supply (+15V) |
| Blue | Negative Supply (0 volts) |
| Black | Output Common |
| Yellow | Output |
| Screen (Shield) | Ground |

WARNING: Do not connect black to ground if blue is grounded.

The output voltage common (black wire) is equal to $((V \text{ supply} - 0.5v)/2)$ which is 7.25 volts when supply is 0v and +15v. The output voltage range of 0 to 3.0 volts (nominal) with respect to the black wire, is 7.25v to 10.25v with respect to 0 volts.

Alternatively, if the supply voltage were set at +7.5V and -7.0V, the o/p common would then be 0V. It is recommended that the transducer body, target and 0V supply are all grounded. If the target is not grounded then there can be a small (e.g. 0.2%) additional non-linearity error.

3.2 Electrical Output Loading

The output voltage (black to yellow) should be measured with a high impedance load. A load as low as 10K ohms connected between output (yellow) and 0 volts (blue) can be driven.

3.3 Connecting to instrumentation

To connect the SENSAGAP to an electronic system, the following points may need addressing:

- (a) Supply voltage, 0 to 15v or $\pm 10\%$ dc 6mA
- (b) Removal of 7.25 volt offset
- (c) Gain adjustment
- (d) Zero adjustment
- (e) Ideally a differential input amplifier should be used to optimise the temperature stability.

The following R.D.P. instruments are suitable for use with SENSAGAP:

- (a) E525 Cypher Transducer Monitor. The DCT input board is required in one of two versions -
 - (i) S.O.12 for use with a single SENSAGAP
 - (ii) S.O.13 for use with a pair of SENSAGAPS
- (b) E308 Transducer Indicator.
 - (i) Latest version (MOD.2 upwards) will work with a single SENSAGAP without the need for any modification.
 - (ii) PD1248 is required for use with a pair of SENSAGAPS
- (c) The S7CT, 611 and E725 DC1 are specifically designed to work with SENSAGAP transducers.

Note: All the above input amplifier configurations are differential except (a)(ii) and (b)(ii).

4. DYNAMIC APPLICATIONS

The maximum response varies with the movement and this is listed in the table below. Note that with this type of transducer there is always a phase lag which can be the limiting factor in certain applications.

| Percentage F.S. | Bandwidth (Hz) | Phase lag (degrees) |
|-----------------|----------------|---------------------|
| 100 | 80 | 6 |
| 80 | 100 | 15 |
| 60 | 250 | 20 |
| 40 | 300 | 24 |
| 20 | 500 | 45 |
| 10 | 1000 | 90 |

In the table percentage F.S. refers to the percentage of the full working range of the transducer, e.g.

80% F.S. on an SG5 model would be a movement of 4mm peak to peak.

5. DUAL TRANSDUCER APPLICATIONS

In certain applications, the use of two SENSAGAP transducers can be beneficial. For example, where a component thickness measurement is required and the component position can vary, then two transducers can be used to provide a thickness signal. The thickness signal will be valid irrespective of the position of the component (see sketch below) so long as it remains within the linear range of both transducers. The R.D.P. instruments E525 - 240 - DCT - 0 - 0 - 13 and E308 PD1248 can be used in this type of application.

A = B = 5mm linear measuring ranges
 E = 3mm component thickness
 C = 3mm gap
 D = 4mm gap

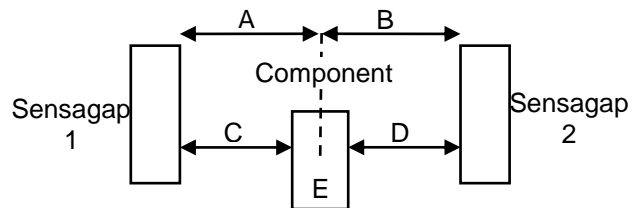

Monitor will read $(A+B) - (C+D) = E = 3\text{mm}$ irrespective of values of C and D, in the range 2 to 5mm, i.e. total allowable movement is transducer full scale (TFS) to TFS - X where X is the component thickness.

Note that the special instrument versions mentioned above do not provide two differential input amplifiers. Where the two inputs are required, the amplifiers are single-ended and this will cause a degradation of the temperature stability to a worst case figure of 0.05% per °C (combined).

6 SPECIFICATION

| | |
|--|--|
| Standard Ranges: | 2.5mm, 5mm, 10mm and 20mm |
| Linearity: | ±0.5% FS or better (0 to 18 mm on SG20). |
| Bandwidth: | Up to 1000Hz (see Section 4) |
| Supply: | 15V ±10% at 6mA. Voltage to be smooth and stabilised |
| Output (for units supplied after 1 st February 1997): | 0 to 3.0V ±10% full scale with a 10k ohm load. Short circuit protected. |
| Output Noise: | Typically 0.1% FS peak to peak |
| Working Temperature Range: | -25 to +85°C for 2.5, 5 & 10mm units -15 to +70°C for 20mm units |
| Relative Humidity: | 0 to 85% non-condensing (see Section 1.4) |
| Shock: | 120g (excluding on ceramic face) |
| Vibration: | 25g (0 to 2kHz) |

Notes

7 WARRANTY AND SERVICE

WARRANTY.

R.D.P. Electronics products are warranted against defects in materials or workmanship. This warranty applies for one year from the date of delivery. We will repair or replace products that prove to be defective during the warranty period provided they are returned to R.D.P. Electronics.

This warranty is in lieu of all other warranties, expressed or implied, including the implied warranty of fitness for a particular purpose to the original purchaser or to any other person. R.D.P. Electronics shall not be liable for consequential damages of any kind.

If the instrument is to be returned to R.D.P. Electronics for repair under warranty, it is essential that the type and serial number be quoted, together with full details of any fault.

SERVICE.

We maintain comprehensive after-sales facilities and the instrument can, if necessary be returned to our factory for servicing.

Equipment returned to us for servicing, other than under warranty, must be accompanied by an official order as all repairs and investigations are subject to at least the minimum charge prevailing at the date of return.

The type and serial number of the instrument should always be quoted, together with full details of any fault and services required.

IMPORTANT NOTES.

1. No service work should be undertaken by the customer while the unit is under warranty except with the authorisation of RDP Electronics.
2. If the instrument is to be returned to R.D.P. Electronics for repair, (including repair under warranty) it is essential that it is suitably packed and that carriage is insured and prepaid. R.D.P. Electronics can accept no liability whatsoever for damage sustained during transit.
3. It is regretted that the above warranty only covers repairs carried out at our factory. Should the instrument have been incorporated into other equipment that requires our engineers to perform the repair on site, a charge will be made for the engineer's time to and from the site, plus any expenses incurred.

The aforementioned provisions do not extend the original warranty period of any product that has been either repaired or replaced by R.D.P. Electronics.

**THIS WARRANTY MAY BE NULL AND VOID SHOULD
THE CUSTOMER FAIL TO MEET OUR TERMS OF PAYMENT.**