



**Technical Manual**

**NON-CONTACT DISPLACEMENT TRANSDUCER  
TYPE PY**

**Doc. Ref CD1031H**



Affirmed by Declaration  
of Conformity

**USA & Canada**  
**RDP Electrosense Inc.**

2216 Pottstown Pike  
Pottstown, PA 19465  
U.S.A.

Tel (610) 469-0850  
Fax (610) 469-0852  
E-mail [info@rdpe.com](mailto:info@rdpe.com)  
[www.rdpe.com](http://www.rdpe.com)

**All other countries**  
**RDP Electronics Ltd**

Grove Street, Heath Town,  
Wolverhampton, WV10 0PY  
United Kingdom

Tel: +44 (0) 1902 457512  
Fax: +44 (0) 1902 452000  
E-mail: [sales@rdpe.com](mailto:sales@rdpe.com)  
[www.rdpe.com](http://www.rdpe.com)

# **PY SERIES HIGH OPERATING TEMPERATURE DISPLACEMENT TRANSDUCER**

## **1. INTRODUCTION**

This series of non-contacting displacement transducers is available in three different measuring ranges and these ranges are available in two different operating temperature ranges.

The PYxxx2 range has an operating temperature range  $-220^{\circ}\text{C}$  to  $+220^{\circ}$  and the PYxxx6 range is  $-220^{\circ}\text{C}$  to  $+600^{\circ}\text{C}$ .

The PY transducer is available as a dual coil (half-bridge) version or a single coil version. The dual coil is generally the most useful. The single coil is used generally in pairs for special applications.

For dimensional and other details refer to the drawing D9355.

## 2. DETAILS OF MI CABLE

- 2.1 The MI cable is insulated with magnesium oxide (MgO) which is hygroscopic. To function correctly the cable should remain sealed at all times. Any ingress of moisture will lower the insulation resistance. The standard cold seal provides a sealed connection from the MI cable cores to the flexible PVC insulated conductors.

The temperature rating of the cold seal is 105°C.

A 2m length of cable is fitted as standard. Lengths of up to 50m may be specified when ordering.

### 2.2 Specification of MI Cable used on High Temperature (600°C) PYxxx6 Transducers

Sheath Material	AISI 316L Chromium Nickel Titanium Stabilised Steel
Sheath Thickness	0.33mm
Sheath Diameter	3.00mm ± 0.03mm
Number of Conductors	4
Conductor Material	Nickel
Nominal resistance per conductor per metre	0.99 ohms ± 15%
Nominal capacitance per conductor per metre	135pF ± 20%
Insulation	Magnesium Oxide
Maximum Cable Operating Temperature	800°C
Maximum External Pressure	In excess of 45000 psig

### 2.3 Specification of MI Cable used on High Temperature (220°C) PYxxx2 Transducers

Sheath Material	AISI 321 Chromium Nickel Titanium Stabilised Steel
Sheath Thickness	0.33mm
Sheath Diameter	3.00mm ± 0.03mm
Number of Conductors	4
Conductor Material	Oxygen free copper
Nominal resistance per conductor per metre	0.19 ohms ± 15%
Nominal capacitance per conductor per metre	135pF ± 20%
Insulation	Magnesium Oxide
Maximum Cable Operating Temperature	600°C
Maximum External Pressure	In excess of 45000 psig

### **3. HANDLING PRECAUTIONS**

- 3.1 Do not bend the cable excessively. Especially avoid bending the cable near the end termination. (Refer to sub-section 4.4 below.)
- 3.2 Ensure the cold seal junction and connecting wires are not heated above 105°C.

### **4. INSTALLATION**

- 4.1 Mount the transducer by clamping the body or using the step made by the larger diameter "flange" to be held by a retaining ring.
- 4.2 The material of the clamp and other metal within 15mm distance of the front area of the transducer should be made from non-magnetic ferrous material, e.g. a 300 grade of stainless steel.
- 4.3 For applications where the PY is to be mounted inside a sealed pressurised enclosure, a compression gland can be supplied, fitted to the MI cable between the transducer and cold seal. Refer to drawing D12470.
- 4.4 The MI cable can be bent, typically to a bending radius of 36mm which can be reduced to 12mm provided bending is effected over a mandrel in one set and without re-straightening.
- 4.5 The effect of cable length variation is not significant, e.g. an increase in cable length, from PY to instrument, from 2m to 10m produces no measurable change in output signal. We can supply transducers fitted with up to 75m of M.I. cable.
- 4.6 Magnetic material (e.g. steel) within 8mm of the PY case typically can change the sensitivity by 5%.

Magnetic material more than 15mm from the PY has a negligible effect.

## 5. ELECTRICAL CONNECTIONS

5.1

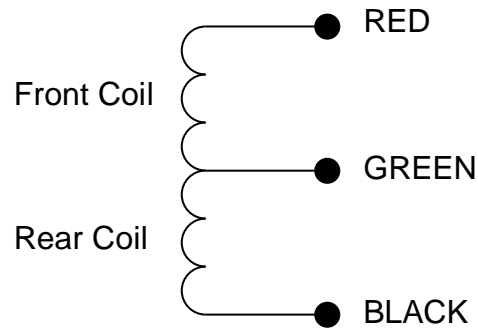

5.2 The transducer can be energised by constant voltage or constant current (10mA) at a frequency of 2.4 to 5.0 kHz.

When used with the 615 instrument, the bridge is completed within the instrument.

## 6.0 CALIBRATION

The PY transducer has a non-linear output signal against displacement, approximately equal to  $1/x$ , where  $x$  is the gap.

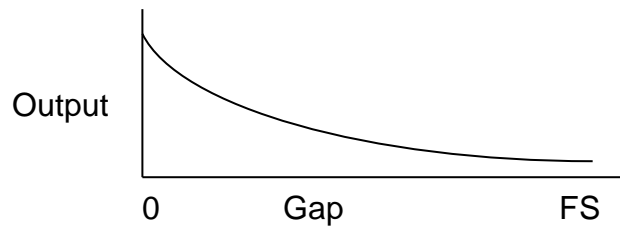

To provide a usable linear signal our 615 instrument has a special linearisation circuit to give an output of 0 to 10 volts or 4-20mA for a gap of zero to full scale.

A transducer can be supplied by us pre-calibrated with the 615 instrument. This calibration can be carried out at a specific elevated temperature.

The 615 has graduated ZERO and SPAN dial and the calibration can be carried out at various different temperatures and the appropriate dial settings for those given.

The E725 monitor has provision for multipoint linearisation which can typically give non-linearities of better than 0.5% with PY transducers.

## **7. OPERATION**

### **7.1 Target**

The target range should cover the front face area of the transducer used, e.g. on a PY256C, the target size should be at least 25mm in diameter.

The target thickness and size can affect the transducer sensitivity by a few percent. For example, on a PY106C with a target diameter of 12mm the sensitivity increases by typically 4% for an increase in thickness from 3mm to 6mm.

With 6mm thick targets, the sensitivity can increase by typically 3% for an increase in target diameter from 12mm to 25mm.

The ideal target material is magnetic, e.g. a 400 grade of stainless steel, mild steel, cast iron, etc.

Non-magnetic targets can be used but will give a de-graded temperature stability. In some cases the non-magnetic target can have a 0.25mm wafer of magnetic stainless steel (or similar) applied to the surface to enable more stable measurements to be made. Consult our Technical Sales Department on specific application details.

### **7.2 Target Movement**

The dynamic response is a function of the excitation frequency and the bandwidth of the associated amplifier.

The R.D.P. linearised output has a bandwidth of 160Hz flat, equating to an approximate linear movement of zero to full scale gap in 3ms.

### **7.3 Cable Length**

The cable length can be varied by up to 40m with no or little effect on the measured signal.

### **7.4 Measuring System Configurations**

Refer to the Technical Manual (CD2013) on our 615 instrument.

## **8. ENVIRONMENT**

### **8.1 Temperature**

The `2' version PY has a working temperature range of -220°C (-365°F) to +220°C (+390°F).

The `6' version PY has a working temperature range of -220°C (365°F) to +600°C (+1110°F).

In each case the survival temperature is considerably higher.

### **8.2 Radiation**

The PYs can withstand nuclear radiation to a total dosage of:-

`2' version PY	:	100 Mega Rads
`6' version PY	:	100,000 Mega Rads

### **8.3 Medium**

These units will work in many different media including water, oil, etc. at pressures up to 200 bar (3000 psi).

## **9. MAINTENANCE AND INSPECTION**

**9.1** The transducer is a fully welded, sealed construction and should not require maintenance.

**9.2** Ensure the cable is correctly installed with no sharp bends. (See Section 4.4).

**9.3** If the transducer becomes suspect, insulation resistance and continuity (loop) resistance checks can be made. Figures for these are on the Calibration Sheet provided with each transducer.

Note that the insulation resistance will fall to a low value when the temperature is high, e.g. 100k ohm at 600°C or 100M ohm at 220°C for the lower temperature version.

## **WARRANTY AND SERVICE**

### WARRANTY.

R.D.P. Electronics products are warranted against defects in materials or workmanship. This warranty applies for one year from the date of delivery. We will repair or replace products that prove to be defective during the warranty period provided they are returned to R.D.P. Electronics.

This warranty is in lieu of all other warranties, expressed or implied, including the implied warranty of fitness for a particular purpose to the original purchaser or to any other person. R.D.P. Electronics shall not be liable for consequential damages of any kind.

If the instrument is to be returned to R.D.P. Electronics for repair under warranty, it is essential that the type and serial number be quoted, together with full details of any fault.

### SERVICE.

We maintain comprehensive after-sales facilities and the instrument can, if necessary be returned to our factory for servicing.

Equipment returned to us for servicing, other than under warranty, must be accompanied by an official order as all repairs and investigations are subject to at least the minimum charge prevailing at the date of return.

The type and serial number of the instrument should always be quoted, together with full details of any fault and services required.

### IMPORTANT NOTES.

1. No service work should be undertaken by the customer while the unit is under warranty except with the authorisation of RDP Electronics.
2. If the instrument is to be returned to R.D.P. Electronics for repair, (including repair under warranty) it is essential that it is suitably packed and that carriage is insured and prepaid. R.D.P. Electronics can accept no liability whatsoever for damage sustained during transit.
3. It is regretted that the above warranty only covers repairs carried out at our factory. Should the instrument have been incorporated into other equipment that requires our engineers to perform the repair on site, a charge will be made for the engineer's time to and from the site, plus any expenses incurred.

The aforementioned provisions do not extend the original warranty period of any product that has been either repaired or replaced by R.D.P. Electronics.

**THIS WARRANTY MAY BE NULL AND VOID SHOULD  
THE CUSTOMER FAIL TO MEET OUR TERMS OF PAYMENT.**