

Technical Manual  
**TRANSDUCER INDICATOR**  
**TYPE E308**

**Doc. Ref CD1601X**

This manual applies to units of mod status 8 ONWARDS



Affirmed by Declaration  
of Conformity

**USA & Canada**  
**RDP Electrosense Inc.**

2216 Pottstown Pike  
Pottstown, PA 19465  
U.S.A.

Tel (610) 469-0850  
Fax (610) 469-0852  
E-mail [info@rdpe.com](mailto:info@rdpe.com)  
[www.rdpe.com](http://www.rdpe.com)

**All other countries**  
**RDP Electronics Ltd**

Grove Street, Heath Town,  
Wolverhampton, WV10 0PY  
United Kingdom

Tel: +44 (0) 1902 457512  
Fax: +44 (0) 1902 452000  
E-mail: [sales@rdpe.com](mailto:sales@rdpe.com)  
[www.rdpe.com](http://www.rdpe.com)

## INDEX

1.	INTRODUCTION .....	4
1.1	<u>IMPORTANT SAFETY TEST INFORMATION</u> .....	4
1.2	Certificate of EMC Conformity .....	5
2.	INSTALLATION INSTRUCTIONS.....	7
2.1	EMC Requirements.....	7
2.2	Power Supply Connection.....	7
2.3	Input and Output Connections Summary.....	8
2.4	Connections to Unamplified Strain Gauge Transducer.....	9
2.5	Connections for Amplified Voltage Output Transducers .....	10
2.6	Connections for Potentiometric Transducers.....	10
2.7	Connections for 3 wire 4 to 20mA Transmitters .....	10
2.8	Connections for 2 wire 4 to 20mA Transmitters .....	10
3.	PANEL CONTROLS .....	11
3.1	Input Level Switch (SW2, Rear Panel).....	11
3.2	Gain Range Switch (SW1, Rear Panel) .....	11
3.3	Fine Gain Potentiometer (Front Panel) .....	11
3.4	Zero Potentiometer (Front Panel) .....	11
3.5	Display Switch - Normal/Limits (Front Panel).....	11
3.6	Limit Level Potentiometers (Front Panel).....	12
3.7	Excitation Potentiometer (RV1, Rear Panel).....	12
3.8	Excitation Check Switch (SW1 - 6, Rear Panel) .....	12
3.9	Cal (Shunt Calibration) Switch (Front Panel, refer to Section 6).....	12
3.10	Decimal Point Switch (DP) (Front Panel) .....	12
3.11	Analogue Output Potentiometer (RV2, Rear Panel) .....	12
3.12	Filter Switch (SW1 - 5, Rear Panel) .....	12
3.13	Display Hold (Connector PL2).....	12
3.14	"Lamp" Test Link (Connector PL2).....	13
4.	INTERNAL CONTROLS .....	14
4.1	Supply Voltage Links .....	14
4.2	Limits Mode Links .....	14
4.3	4mA Output Potentiometer (RV7) .....	15
4.4	Zero Suppressions Resistors .....	15
4.5	4-20mA Input Scaling Resistor (R13).....	15
5.	SETTING UP PROCEDURE.....	16
6.	SHUNT CALIBRATION.....	17
6.1	A Calibration Check .....	17
6.2	A Secondary Calibration .....	17
7.	SPECIFICATION .....	18
8	APPLICATION NOTES.....	20
8.1	Electrical Interference Problems .....	20
8.2	BENCH/PORTABLE INSTRUMENT.....	21

## Table of Figures

Fig. 1	Front and Rear Panels .....	6
Fig. 2	Internal controls .....	13
Fig. 3	Limits graphic with normal mode-link setting.....	14

# 1. INTRODUCTION

The E308 is a comprehensive transducer indicator instrument providing signal transducers such as load cells, etc. and for transducers with built-in electronics producing high output (e.g. 5 volts) signals.

Features include:

- a) Stable bridge excitation and amplifier with ratiometric excitation/display reference circuitry.
- b) Switch-selection of high gain (millivolts input) or low gain (volt input) signal amplification.
- c) Coarse and Fine Gain controls and zero control.
- d) Continuously variable excitation voltage.
- e) Standard  $\pm 10\text{v}$  and 4-20mA analogue outputs.
- f) Shunt calibration check.
- g) Bench or panel mounting versions.
- h) Two independent limit detectors with changeover relay contacts.
- i) Display hold and lamp test facilities.
- j) Display switch to indicate excitation voltage.
- k) Decimal point selection via front panel switch.
- l) Filter switch for noise reduction.
- m) Shielded connection for improved EMC.
- n) Robust metal case

## 1.1 IMPORTANT SAFETY TEST INFORMATION.

### ELECTRICAL SAFETY CHECKS

This instrument was checked for electrical safety, using a portable appliance test instrument, prior to despatch.

If the user wishes to carry out his own tests, the following points must be followed:

- (1) This Safety Class 1 apparatus has a low (<3A) fuse rating and a low current rated power connection cable.
- (2) It is recommended that when carrying out an earth bond test (BS EN 61010-1 Section 6), the test current of 25A should not be applied for more than **six seconds**.
- (3) In general it is **not** recommended that high voltage (e.g. 1.5kV) insulation tests are carried out (BS EN 61010-1, Section 6). This could cause damage to suppressor components.

# **DECLARATION OF CONFORMITY**

**RDP ELECTRONICS LTD.**  
**Grove Street, Heath Town**  
**Wolverhampton, West Midlands**  
**WV10 0PY**  
**United Kingdom**

We declare that the product described in this technical manual is manufactured by RDP Electronics Limited and performs in conformity to the following:

The Electromagnetic Compatibility Directive 2014/30/EU

The Low Voltage Safety Directive 2014/35/EU

RoHS Directive 2011/65/EU

**R D Garbett**  
**Director**  
**RDP Electronics Limited**

Fig. 1 Front and Rear Panels

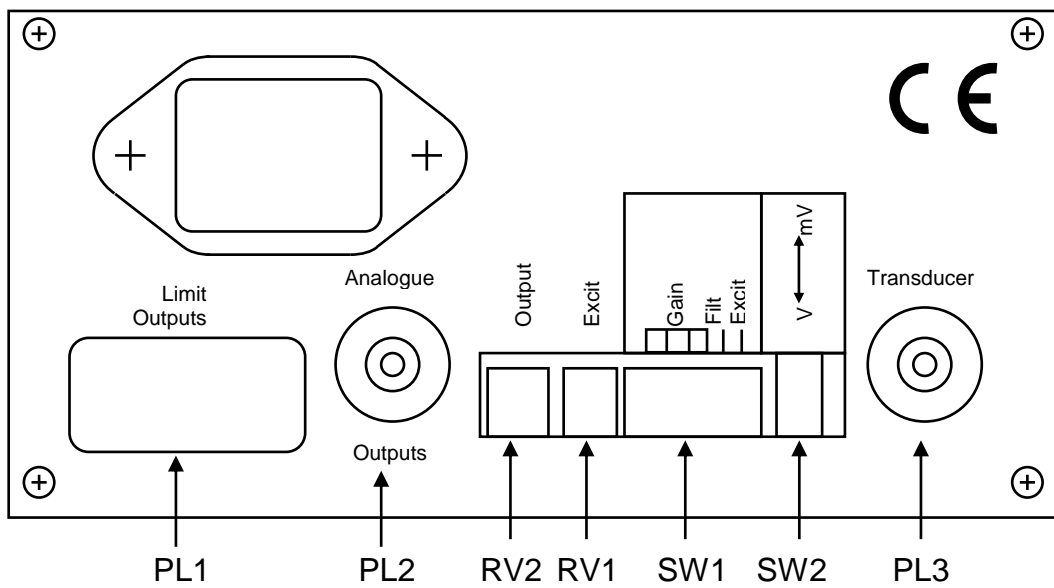
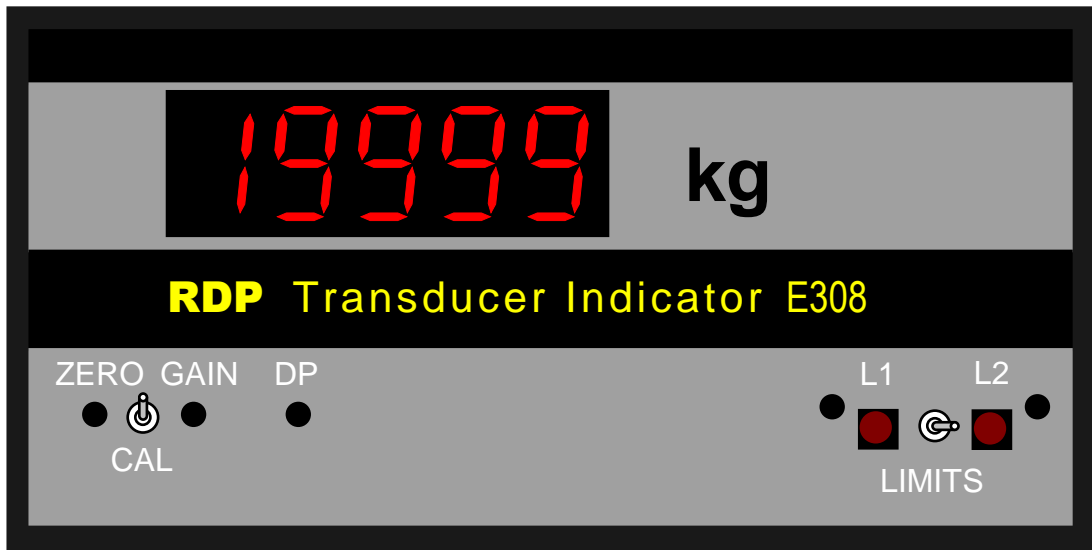

## **2. INSTALLATION INSTRUCTIONS**

### **2.1 EMC Requirements**

For full EMC compliance, only shielded multi-core cables should be used for connection to this instrument; the cable shield to be terminated by means of a short "pig-tail" and connected to the connector cover.

The metal case should be earthed (grounded). This would usually be achieved via the green/yellow core of the supply cable.

#### **NOTES**

- 1 Cable shields to be earthed at only one end - the instrument end.
- 2 When the instrument is a small part of a large electrical installation, ensure the cables to and from the instrument are segregated from electrically noisy cables.
- 3 Ensure cables to and from the instrument are routed away from any obviously powerful sources of electrical noise, e.g. electric motors, relays, solenoids.
- 4 ESD precautions should be used when working on the instrument circuit board with the lid removed. The user should ensure he is "earthed" by use of an earthed wrist strap or at least touching earth before touching any component including wires, terminals or switches.
- 5 The body of the transducer should be earthed. If the transducer fixing attachments do not provide a good earth, then an earth strap should be used.

**Refer to Section 8 where electrical interference may be a problem.**

### **2.2 Power Supply Connection**

The ac supply is connected via a 2 metre, 3-core cable (supplied) as follows:-

LIVE (120/240v)	-	BROWN
NEUTRAL	-	BLUE
EARTH/GROUND	-	GREEN and YELLOW

Where a unit has an internal supply fuse, the value will be indicated in the specification. If no fuse is specified, then an external one should be fitted, of the anti-surge type, with a value commensurate with the VA rating of the unit as specified.

Units should always be grounded via the supply for reasons of safety and electrical noise. The green and yellow wire is normally internally connected to the instrument common or 0V line and hence to the transducer cable shield.

Refer also to the section on internal controls for details of supply voltage selection, and to the Application Note on electrical interference.

## 2.3 Input and Output Connections Summary

Refer also to Figs. 1, 2 and Rear Panel Printing.

All transducer, analogue output and relay output connections are made via DIN and D-type connectors at the rear of the instrument as shown below:

FUNCTION		PIN No.	CONNECTOR
Limit Relay 1 (Note 2)	N.O.	5	PL1 Limits Output 9-way plug (D type)
	Common	4	
	N.C.	3	
Limit Relay 2 (Note 2)	N.O.	2	
	Common	1	
	N.C.	9	
Logic Outputs	Limit 2, Limit 1	7, 8	
Logic/Digital Common (Mod.15 units onwards only)		6	
Display Hold Input		1	
Lamp Test Input		2	
Analogue Output $\pm 10V$		3	
Analogue Output Common/0V		4	
Analogue Output 4-20mA		5	
Shunt Cal 1 (transmitters only)		6	
Digital Common		7	
Excitation +		1	PL3 Transducer 7-way plug (DIN type)
Excitation -		2	
Signal + (Note 3)		3	
Signal - (Note 3)		4	
Shunt Cal.		5	
Cable Shield (Note 1)		6	
-15V Output		7	

### Note 1

The transducer cable shield should be terminated at one end of the cable only - preferably at the instrument end (terminal 6) - to avoid ground-loop problems. Pin 6 is internally connected to common (ground) but it is preferable to connect the shield to the connector body instead of Pin 6.

### Note 2

The limit relay contacts should only be used to switch:

- a) Dc resistive or reverse-diode protected inductive loads,
- b) Ac resistive loads.

Ac coils should be operated via a slave dc relay or SCR module.

### Note 3

The unit should not be powered up with the transducer signal terminals floating (open circuit) as mains pick-up may cause the limit relays to oscillate at supply frequency. The inputs may be temporarily linked to 0v (e.g. terminal 6) if required.



## 2.4 Connections to Unamplified Strain Gauge Transducer

### Without shunt calibration.

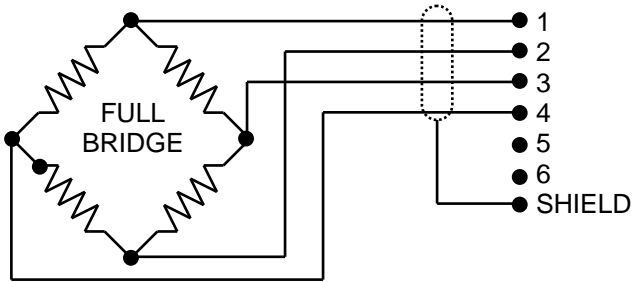

1	Excitation +
2	Excitation -
3	Signal +
4	Signal -
5	No connection
6	0V (no connection)
Shield	Connect to shell of connector

### With shunt calibration - simple approach.

This approach is suitable for short cables typically <5m. For longer cables and for optimum accuracy use 'best approach' shown below.

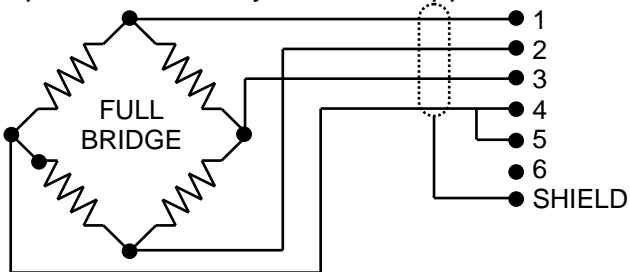

1	Excitation +
2	Excitation -
3	Signal +
4	Signal -
5	Shunt Cal
6	0V (no connection)
Shield	Connect to shell of connector

### With shunt calibration - best approach using E308

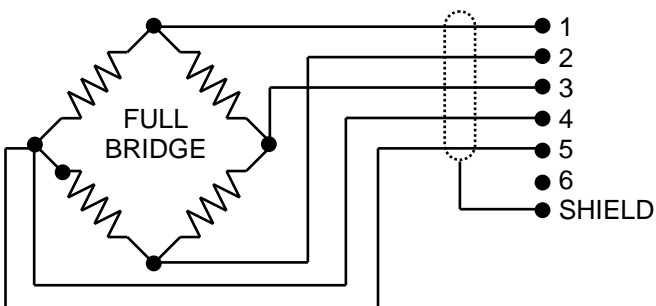

1	Excitation +
2	Excitation -
3	Signal +
4	Signal -
5	Shunt cal
6	0V (no connection)
Shield	Connect to shell of connector

## 2.5 Connections for Amplified Voltage Output Transducers

The example shows a sensor that requires a 15V supply and has a voltage output. As the input to the E308 is floating, the common of the transducer need not be 0V.

Other supply arrangements may be required. Refer to CONNECTIONS TABLE for alternatives.

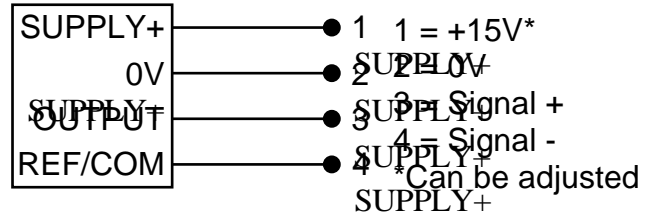

## 2.6 Connections for Potentiometric Transducers

\*The example shows a potentiometric transducer operating from a 10V supply.

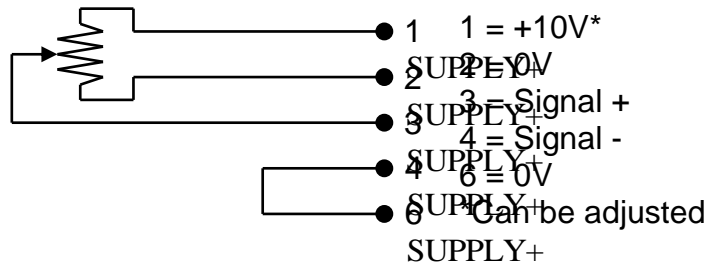

## 2.7 Connections for 3 wire 4 to 20mA Transmitters

The example shows a 3 wire 4-20mA transmitter with a 30V supply. Fit the resistors inside the connector.

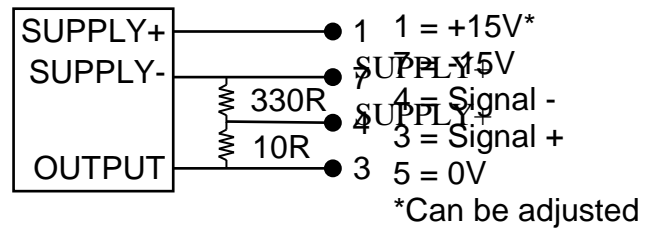

## 2.8 Connections for 2 wire 4 to 20mA Transmitters

The example shows a 2 wire 4-20mA transmitter with a 12/24V supply. Fit the resistor inside the connector.

For 24V supply, change the internal solder link SP2 to C-D. See section 4 for details of opening the unit.

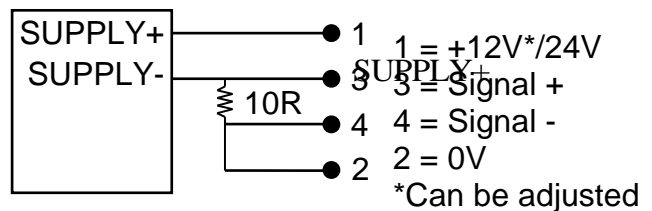

### 3. PANEL CONTROLS

Refer also to Fig.1.

Note: all potentiometers are 20-turn, screwdriver adjusted.

#### 3.1 Input Level Switch (SW2, Rear Panel)

This slide-switch selects either high gain mode for mV level input signals, or low gain mode for 1-10V level input signals.

Set to UP for mV inputs, DOWN for V inputs. When used in conjunction with the gain range switch and fine gain controls, allows a full scale output to be obtained with a wide range of input signals.

#### 3.2 Gain Range Switch (SW1, Rear Panel)

Four levers or keys of a piano-type switch are used to select the input signal range, either in high gain or low gain mode, as shown below:

Gain Range	Key ON (Down)	mV Input Range (High Gain)	V Input Range (Low Gain)
1	2 + 3 + 4	5 – 10	1.7 – 3.4
2	4	8 – 17	3 – 5
3	3	17 – 34	5 – 11
4	2	34 – 64	11 – 22
5	1	64 – 130	22 – 45
6	None	130 - 260	45 – 90

(Note: these are the signals required for full scale display/output).

For example, with gain range 3 selected, full scale display/output can be obtained with a signal of 17mV with the Fine Gain Potentiometer (see 3.3) at maximum, ranging to 34mV with the potentiometer at minimum.

If a display of considerably less than full scale is required, then select a lower-gain range. For example, to display 5000 for a 17mV signal, then reduce the gain by  $5000/19999 = 1/4$  by choosing a range with 4 x the input signal (4 x 17), i.e. range 5 (64 - 130mV). Operation is similar with the V Input Ranges.

#### 3.3 Fine Gain Potentiometer (Front Panel)

This allows a gain adjustment of about 2 : 1 and is effective on both the display and analogue outputs. Interpolates between the gain ranges selected by SW1.

#### 3.4 Zero Potentiometer (Front Panel)

This allows fine adjustment of the display and analogue output. Its range depends on the Fine Gain setting.

#### 3.5 Display Switch - Normal/Limits (Front Panel)

In the central position, this 3-way switch connects the display to indicate the transducer signal, i.e. normal mode.

When set to the left (L1), the display indicates the level of limit 1. When set to the right (L2), the display indicates the level of limit 2.

### **3.6 Limit Level Potentiometers (Front Panel)**

These allow setting of the limit values over the full range of the instrument, i.e.  $\pm 19999$  digits. The display is used to monitor the settings as detailed in 3.5 above.

### **3.7 Excitation Potentiometer (RV1, Rear Panel)**

This provides continuous variation from 0V to a maximum of nominally 15V. This may be monitored via the excitation check switch as detailed below.

### **3.8 Excitation Check Switch (SW1 - 6, Rear Panel)**

Setting key 6 of the switch to OFF (up) causes the display to indicate approximately the excitation voltage with a scaling of 1000 digits/Volt (e.g. 10000 digits = 10V, etc.) Any decimal point indicated should be ignored in this mode.

### **3.9 Cal (Shunt Calibration) Switch (Front Panel, refer to Section 6)**

This is set in the UP position for normal use. When set in the DOWN position it connects an internal precision resistor across one arm of the transducer bridge, where applicable. See Section 2.4.

### **3.10 Decimal Point Switch (DP) (Front Panel)**

This is a screwdriver-adjusted rotary switch. Note that the switch is a BCD coded type and in some positions two or three points may be indicated simultaneously: continue rotating the switch until the required point is lit.

### **3.11 Analogue Output Potentiometer (RV2, Rear Panel)**

Refer also to Section 7.

This provides an adjustment of the analogue voltage/current scaling. It is normally set so that full scale display ( $\pm 20000$  digits) corresponds to  $\pm 10V$  or 20mA output.

Note that the 4mA output level is set via an internal control described in section 4. The normal setting is for zero display to correspond to 4mA output.

### **3.12 Filter Switch (SW1 - 5, Rear Panel)**

Key 5 of the rear panel switch, when set to ON, connects an internal capacitor which reduces the amplifier bandwidth and hence output noise.

### **3.13 Display Hold (Connector PL2)**

Applying a TTL Low between pins 1 and 7 (common) or linking via a switch or relay (e.g. limit relay) etc. will freeze the display.

#### **Timing**

Normally the display is updated at a rate of  $2\frac{1}{2}$  times/second, or every 400mS. When a HOLD is applied, the A-D converter will continue its full cycle before holding the display.

The display will remain held as long as HOLD is low, but a high pulse of >300nS will initiate a new measurement cycle. If another pulse occurs before the cycle is complete, it is ignored.

### 3.14 "Lamp" Test Link (Connector PL2)

Applying a TTL Low between pins 2 and 7 (common) or connecting pin 2 of the output connector (PL2) to pin 7 (common) via a switch, etc. will produce a 18888 display. This checks that all segments of the LED displays are working.

Fig. 2 Internal controls

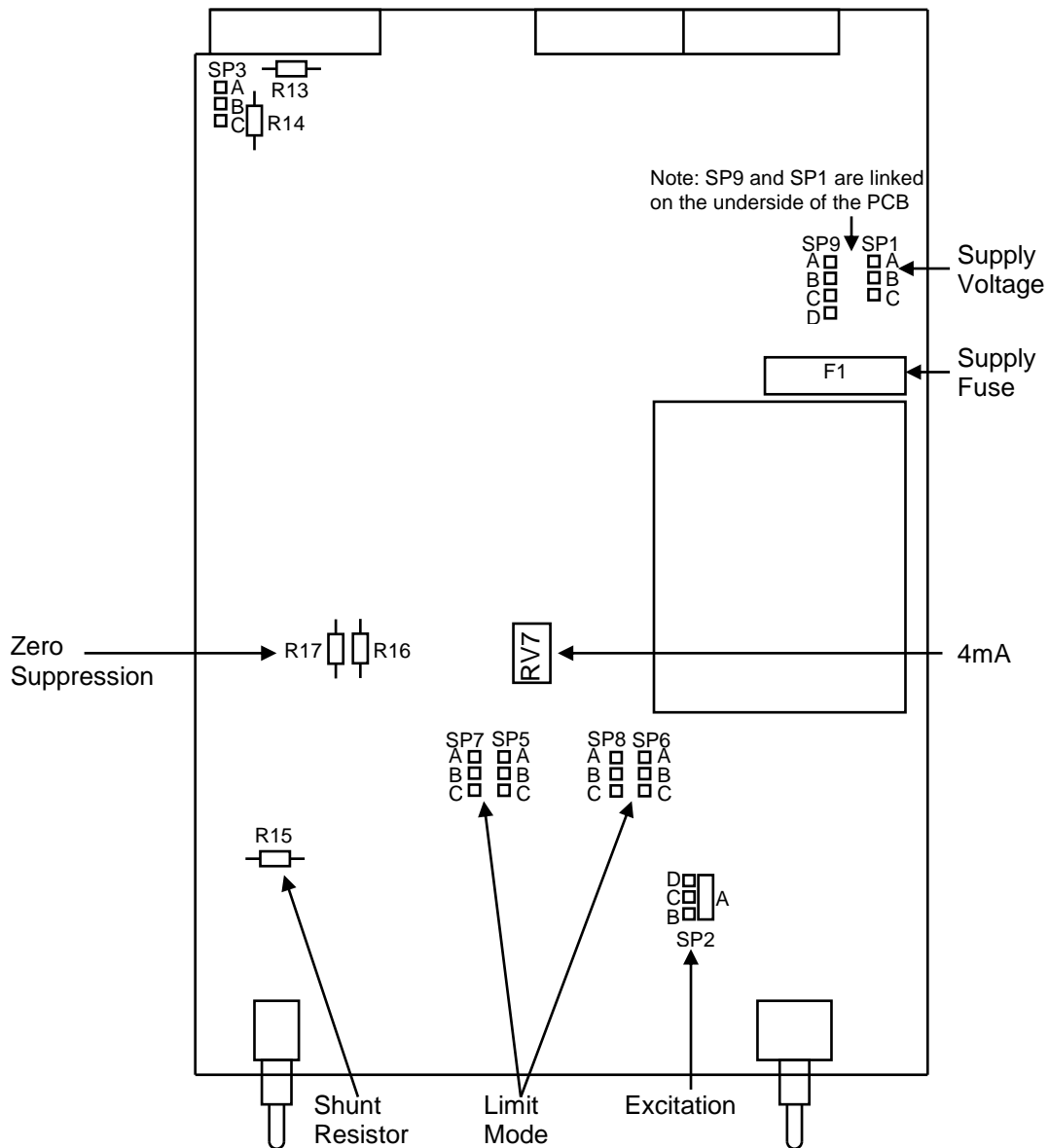

## 4. INTERNAL CONTROLS

(Refer to Fig.2 for locations)

### FIRST DISCONNECT THE SUPPLY

These controls (solder links/potentiometers) are accessible on removing the six rear panel fixing screws and sliding the circuit board and panel rearwards.

#### 4.1 Supply Voltage Links

Various supply voltages may be used on selection of the correct solder links as shown below. Units are normally supplied set for 240v use.

Nominal Supply Voltage	SP1	SP9
240	B – C	B – C (Normal)
120	B – C	A – B, C - D

#### 4.2 Limits Mode Links

If limit operation is not required, then they may be disabled (switched off) by setting Limit 1 potentiometer fully counter-clockwise and Limit 2 fully clockwise.

Units are normally supplied so that:-

The relay of Limit 1 is normally energised until the signal goes **more positive** than the set point, i.e. as a fail-safe "High" limit.

The relay of Limit 2 is normally energised until the signal goes **more negative** than the set point, i.e. as a fail-safe "Low" limit.

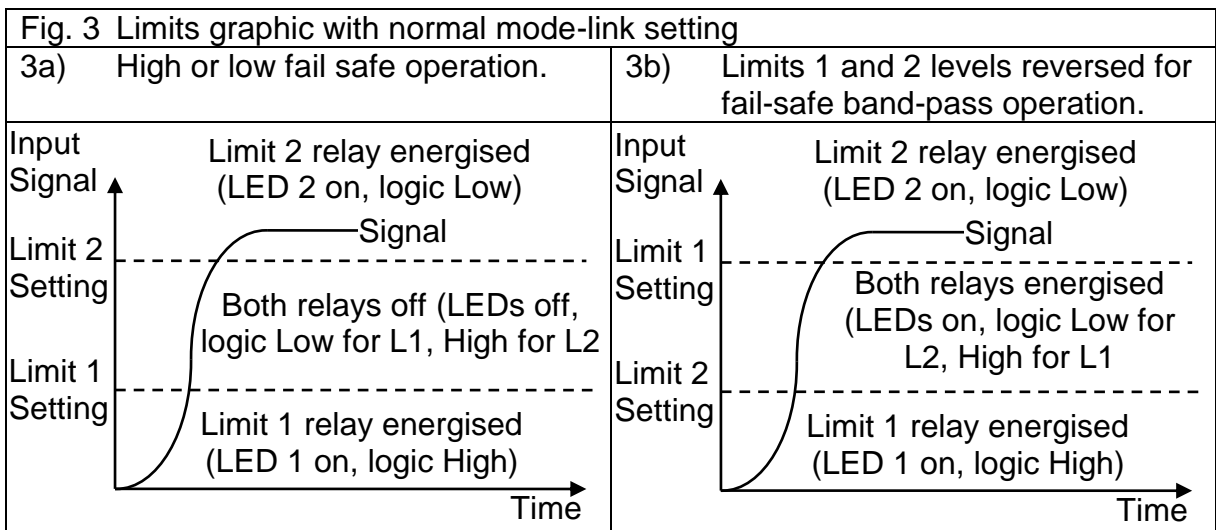

Operation of each limit may be reversed by changing solder links as shown below:

Limit	Links	Fail-Safe High	Fail-Safe Low
L1	SP5 + SP7	B-C	A-B
L2	SP6 + SP8	B-C	A-B

The normal settings are Limit 1 as a "high" limit and Limit 2 as a "low" limit. This allows setting a fail-safe pass-band between the two limits.

To change a limit mode, both relevant links for that limit must be changed, e.g. to change L1 to a "low" limit, change **both** SP5 **and** SP7 to A-B.

Note that in all modes, when a relay is energised, its corresponding LED is lit.

## Logic Outputs.

The limits logic outputs are low (0) when the signal is more positive than the limit value and high (1) when the signal is more negative than the limit value.

The logic is not affected by the reversing links SP5 - SP8 which operate only on the relays and LEDs.

### 4.3 4mA Output Potentiometer (RV7)

Normally this is set so that zero display = zero output voltage = 4mA output current. This control allows adjustment of the current "offset", shifting both the 4mA and 20mA points simultaneously with respect to the display.

By adjusting this control in conjunction with the rear panel output potentiometer, it is possible to obtain a 4-20mA (or 0-20mA etc.) with any display scaling over the range -19999 to +19999, by the following method:

- a) Obtain the required display scaling via the normal zero and gain controls.
- b) Set the transducer to mid-range position and adjust RV7 for 12mA output (half way between 4 and 20mA).
- c) Set the transducer for full scale position and adjust the rear panel output potentiometer for 20mA.
- d) Set the transducer to the zero position and check for 4mA output.

### 4.4 Zero Suppressions Resistors

Mounting pins are provided for fitting resistors (R16 and R17) to offset the display if the zero control range is insufficient. The value will depend on the shift required and the Fine Gain control setting. The table below shows some approximate "Ω/digit) relationships for guidance, with the Fine Gain set at mid-range:

<b>Resistor</b> (high stability resistors should be used.)	470k	680k	1M	2M2
<b>Display Shift</b> (Positive for R17, Negative for R16)	20000	14000	9000	4000

### 4.5 4-20mA Input Scaling Resistor (R13)

The value of this resistor determines the relationship between input signal value (mA) and the range of display/analogue output provided.

The resistor should be high stability type and the higher the value the more stable will be the E308 display/output. The maximum value will depend on the specification of the transducer supplying the signal.

Ohm's Law will provide a voltage signal derived from R13 which may be substituted in the signal range table of Section 3.2. (The recommended range is 5Ω to 13Ω for High Gain settings, or 85Ω to, say, 500Ω for Low Gain settings.)

For example, if R13 = 10Ω, then the voltage developed across it and hence applied to the E308 amplifier for a current of 20ma will be:-  $10 \times 0.02 = 0.2v$

From the table, this indicates the use of Gain Range 6, depending on the full scale display required, as detailed in the note for Section 3.2.

## 5. SETTING UP PROCEDURE

Note: If factory-calibrated, steps 1 – 9 may be ignored.  
For 4-20mA scaling, refer also to section 4.5.

- 5.1 Refer to section 6 re: shunt calibration, to determine the calibration method to use.
- 5.2 Refer to section 4 and adjust the internal controls if necessary. **CHECK SUPPLY VOLTAGE IS CORRECT.**
- 5.3 Connect analogue output, limit relays, etc. as detailed in section 2. **NEVER** operate the unit with an open-circuit signal input for more than a few seconds as this may cause the relays to oscillate at supply frequency.
- 5.4 Set the Input Level switch and Gain Range switch as shown in section 3, i.e. UP for mV signals, DOWN for V signals.
- 5.5 Switch on and check that the display illuminates. Check the excitation voltage by setting the rear panel key 6 to OFF (up) Section 3). Adjust the rear panel control (RV1) if necessary  
[Note 1000 digits/volt display, e.g. 10000 = 10v ( $\pm 5\%$ )]. Reset key 6 down.  
**WARNING**, excessive excitation voltage or incorrect connections could irreperably damage the transducer.
- 5.6 The display should now indicate the transducer signal. (A flashing display indicates an overrange or open-circuit input). If a fault is suspected, unplug the transducer and link transducer pins 3-4-6, i.e. both signal inputs to ground. This should produce a near-zero display with the zero control at about mid-range.
- 5.7 With the transducer connected and no load/pressure, etc. applied, adjust the zero control for zero display (if the range of the zero control is inadequate, refer to section 4.4).
- 5.8 Calibrate the display, either by the Shunt Cal. method described in section 6, or by applying a known load/pressure, etc. and adjusting the Fine Gain control.  
  
Repeat steps 5.7 and 5.8 for consistent results.
- 5.9 Set the decimal point position via the front panel switch as detailed in section 3.10.
- 5.10 If limit trips are required, set the limit levels by setting the display switch to the relevant limit position and adjusting the associated potentiometer for the desired level as indicated on the display. To alter the limit mode, e.g. change a high limit to a low limit, etc. refer to section 4.2.
- 5.11 The front panel may be labelled in engineering units by using one of the transfers from the sheet provided.



## 6. SHUNT CALIBRATION

Shunt calibration is the term applied to the method of connecting a precision resistor (usually 59K 0.1%) across one arm of a resistance bridge to check or set an amplifier gain, etc. It is appropriate for transducers supplied with a shunt calibration figure.

There are two ways of using shunt calibration:-

### 6.1 A Calibration Check

If the prime calibration has been made by applying a precisely known load or pressure to the transducer, (refer to section 5) then the CAL switch may be operated (with load removed) and the display recorded as a calibration check figure. A quick check can then be made at any time by comparing new shunt calibration readings with the original.

**Note:** If the reading is not at zero when the switch is operated, the true calibration check figure is the shunt calibration reading less the initial reading. If desired, the Fine Gain control may be adjusted (and/or zero) to restore the original display.

### 6.2 A Secondary Calibration

Using the shunt calibration figure from the Transducer Calibration Certificate, one may use the shunt calibration method to calibrate a system accurately without recourse to known loads or pressures. The procedure is:

- (a) Calculate the shunt calibration figure required from the Calibration Certificate

From Transducer Calibration Certificate,  
Output for 100% = W mV  
Output with shunt = Y mV

Therefore the reading required in CAL is:  $Y/W \times$  required full scale reading.

**Note:** If the Calibration Certificate states shunt resistor different from the one fitted (59K ohm is standard: other values to order), then it may still be possible to obtain a calibration from:

$$\text{CAL figure calculated} \times (\text{shunt} / 59\text{k}) = \text{New CAL figure}$$

- (b) Having checked the excitation voltage is appropriate, connect up transducer. Apply power to the E308 and allow a 20 minute warm-up (for optimum accuracy).

**Note:** The shunt calibration circuit should be connected (see section 2.4), note that cable length is a factor affecting the choice of connection

- (c) Ensure no load or pressure applied to the transducer.
- (d) Operate CAL switch and adjust Fine Gain control to give the required reading as calculated in (a) above.

## 7. SPECIFICATION

### Display

Display Size	11mm (0.43in) 7-segment high-brightness red LED
Range	±19999
Polarity Indicator	- sign displayed
Over-range	Flashing display
Decimal Points	4 positions via selector switch
Hold and Lamp Test	via rear terminal connections to common
Sample Rate	400mS

### Power Supply

Voltage	240V ac (+5-20%) std. or 120V ac (+5-20%) selected via solder links
Power	10VA typical
Fuse	250mA A/S 20mm

### General

Operating Temperature	0°C to 50°C
Storage	-40°C to 85°C
Weight	1.3kg/2.9lb

### Case

Material	Anodised Aluminium
Bezel size	144 x 72mm overall
Depth	185mm (behind bezel excl. connectors: 245mm incl. connectors)
Panel cut-out	139 x 67mm

### Amplifier

Input /range (for 19999 display)	5-260mV or 1,7 – 90V via mode selector switch and Gain Range switch
Input Resistance	2MΩ
Linearity	±0.02% F.S. typical
Zero Stability	Display & Voltage Output: 0.2μV/°C RTI mV mode, typical; 20μV/°C RTI V mode typical 4-20mA Output: as Display & Voltage Output plus 2μA/°C RTO typ.
Gain Stability	0.005% F.S./°C typical for Display: 0.01% for Analogue Output. Optimum at ± full scale.
Bandwidth	150Hz (flat) standard: 3Hz (flat) with filter on – typical
Noise (mV mode) p-p	2mV RTO + 20μV RTI typical: 2mV RTO + 5μV RTI with filter on
Noise (V mode) p-p	4mV RTO typical
CMRR (DC-50Hz)	60dB typical
Output Voltage	±10V at 5mA
Output Current	4-20mA into 0 to 500 ohms. This is an active output that should not be connected to any external power supply as this will damage unit.
Protection	Short circuit proof
Note:	Outputs normally factory-set so that ±19999 display corresponds to ±10V and 0 to +19999 display to 4-20mA

## Excitation

Voltage	Continuously variable from 1.2V to +15V ( $\pm 5\%$ ) at 1.2VA or 120mA max. -15V available at 60mA max. Both short circuit proof.
Stability	0.005%/°C typical

## Controls

Zero adjustment range	$\pm 2000$ to $\pm 5000$ digits according to Fine Gain setting
Coarse Gain range	5 ranges via rear panel switch
Fine Gain range	2 : 1 via 20-turn potentiometer
Shunt Cal	59k, 0.1%, 25ppm resistor
Analogue Output	Zero potentiometer range 0 to 10mA (for zero display). Gain potentiometer allows setting 10V output for displays between 2400 and 19999.
4mA Adjustment range	Allows 4mA to be set for any display value

## Limits (Refer also to Section 8)

Set point range	$\pm 19999$ via 20-turn potentiometer
Display Indication	3-way switch for limit 1/normal/limit 2 levels 2 LEDs on when relays on
Mode	Positive or negative going operation selected via solder links
Relays	2 changeover contact types. 0.3A at 120V ac/1A at 24V dc. Operating time 5mS (refer to Bandwidth above)
Mechanical Life	$> 12 \times 10^6$ operations
Accuracy	$\pm 0.1\%$ of full scale typical
Hysteresis	$\pm 0.05\%$ of full scale typical
Logic outputs	TTL outputs. Source 2mA, sink 10mA

## Connectors

Transducer/Analogue Output	7-pin DIN shielded. Contact resistance $\equiv 10\text{m}\Omega$ . Case grounded by socket.
Limits Output	9-pin D type. Case grounded by rear panel. For max. V and I see relay specification above.
EMC Specification	When subjected to radiated electro-magnetic energy (as EN61000-4-3) an additional error can occur at certain frequencies:-

Field Strength	Typical Maximum Error
10V/m	1.5%
3V/m	0.5%

## 8 APPLICATION NOTES

### 8.1 Electrical Interference Problems

When an E308 Transducer Indicator is used in an industrial application, some of the following points may be helpful to System Engineers to design a trouble-free installation.

- 8.1.1 In general the operation of electronic instruments and transducers can be affected by electrical interference.
- 8.1.2 This interference can be generated by the switching of large or reactive loads on the supply, causing the production of large voltage spikes and/or variation in the ac mains supply.

Higher frequency interference (radio frequency) is often generated by a large voltage (e.g. back emf from a coil) being switched by a contact. Generally a contact seen to arc whilst switching is producing RF interference.

- 8.1.3 The interference "signals" can enter a transducer measuring system in the following ways:
  - a) Direct pick-up by wiring to the instrument. The wiring can be a connection to the transducer supply input or control (e.g. trip relay).
  - b) Direct pick-up into the instrument.
  - c) Along the mains supply lines.

- 8.1.4 There are two methods of countering these problems:

- a) Suppress the interference generation at source.
- b) Prevent the interference gaining access to the instrumentation circuitry.

- 8.1.5 Suppression at source is often the best approach. AC coils can often effectively be suppressed by means of connecting, as close to the coil terminals as possible, a 100 ohm resistor in series with 0.1 $\mu$ F across the coil. Proprietary transient voltage clippers - either non-linear resistor or better semiconductor types - are very useful for suppression, mounted across coils and contacts.

- 8.1.6 An electrically noisy mains supply can be suppressed by means of a mains filter unit. These units in their simplest form consist of capacitors and inductors. Mounted at the point where the mains enters the instrument, they can be most effective. A constant voltage transformer is another effective way of cleaning up the mains.

- 8.1.7 Extra shielding of the transducer, cabling and instrument is a simple, low cost method of preventing particularly directed radiated RF type of interference.

Shielded cable should always be used to connect the transducer to the instrument. Shielded cable is often beneficial for other connections as well. The shield should only be earthed at the instrument end.

It is not good practice to mount the instrument near to contactors, motors, switch transformers, solenoids, etc. But where it is considered necessary to mount the instrument near to such devices, an extra steel enclosure around the instrument would be essential.

In extreme cases, the transducer cable should be run in a steel conduit.

8.1.8 Trip relays fitted inside the E308 should never be used to switch ac coils. The recommended arrangement is to use a dc slave relay as shown below.

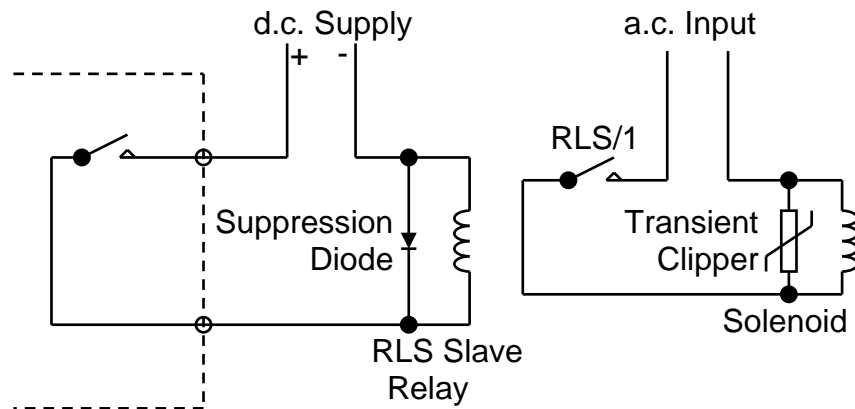

Wherever possible, TTL limit outputs should be used to:

- a) reduce noise problems,
- b) increase response speed,
- c) increase life especially in repetitive applications where relay contact life may be significant.

## 8.2 BENCH/PORTABLE INSTRUMENT

The bench instrument (BI) version of the E308 instrument is a standard E308 mounted in an additional case incorporating the following features:

- (a) extra physical protection
- (b) carrying handle
- (c) front panel dial-type ZERO control.

The standard E308 Technical Manual is applicable except that the overall dimensions of the BI case are:

Height	94mm
Width	216mm
Depth	235mm

and the weight is 2.1kg (4.6lb)

## Notes

## Notes

## 9 WARRANTY AND SERVICE

### WARRANTY.

R.D.P. Electronics products are warranted against defects in materials or workmanship. This warranty applies for one year from the date of delivery. We will repair or replace products that prove to be defective during the warranty period provided they are returned to R.D.P. Electronics.

This warranty is in lieu of all other warranties, expressed or implied, including the implied warranty of fitness for a particular purpose to the original purchaser or to any other person. R.D.P. Electronics shall not be liable for consequential damages of any kind.

If the instrument is to be returned to R.D.P. Electronics for repair under warranty, it is essential that the type and serial number be quoted, together with full details of any fault.

### SERVICE.

We maintain comprehensive after-sales facilities and the instrument can, if necessary be returned to our factory for servicing.

Equipment returned to us for servicing, other than under warranty, must be accompanied by an official order as all repairs and investigations are subject to at least the minimum charge prevailing at the date of return.

The type and serial number of the instrument should always be quoted, together with full details of any fault and services required.

### IMPORTANT NOTES.

1. No service work should be undertaken by the customer while the unit is under warranty except with the authorisation of RDP Electronics.
2. If the instrument is to be returned to R.D.P. Electronics for repair, (including repair under warranty) it is essential that it is suitably packed and that carriage is insured and prepaid. R.D.P. Electronics can accept no liability whatsoever for damage sustained during transit.
3. It is regretted that the above warranty only covers repairs carried out at our factory. Should the instrument have been incorporated into other equipment that requires our engineers to perform the repair on site, a charge will be made for the engineer's time to and from the site, plus any expenses incurred.

The aforementioned provisions do not extend the original warranty period of any product that has been either repaired or replaced by R.D.P. Electronics.

**THIS WARRANTY MAY BE NULL AND VOID SHOULD  
THE CUSTOMER FAIL TO MEET OUR TERMS OF PAYMENT.**