

Technical Manual
TRANSDUCER AMPLIFIER
TYPE 615

Refer also to 600 System Manual CD2010 and
PY Transducer Manual CD1031 (if used with a PY) or
LIN Transducer Manual CD1019 (if used with a LIN)

Doc. Ref CD2013W

This manual applies to units of mod status 9C ONWARDS



Affirmed by Declaration
of Conformity

USA & Canada
RDP Electrosense Inc.

2216 Pottstown Pike
Pottstown, PA 19465
U.S.A.

Tel (610) 469-0850
Fax (610) 469-0852
E-mail info@rdpe.com
www.rdpe.com

All other countries
RDP Electronics Ltd

Grove Street, Heath Town,
Wolverhampton, WV10 0PY
United Kingdom

Tel: +44 (0) 1902 457512
Fax: +44 (0) 1902 452000
E-mail: sales@rdpe.com
www.rdpe.com

BLANK PAGE

INDEX

1.	INTRODUCTION & ESSENTIAL READING.....	5
1.1	Before Powering-up Check	7
1.2	Information on Conformity to EC Directives.....	7
2.	TRANSDUCER & OUTPUT CONNECTIONS	8
2.1	Transducer connections with 600 Backplane	8
2.2	Output Connections with 600 backplane	8
2.3	OUTPUT CONNECTIONS VIA FRONT PANEL JACK PLUG	8
2.4	Transducer & output connections using 32-way (DIN 41612) connector.....	9
3.	CONTROLS : FRONT PANEL	10
3.1	Span Dial	10
3.2	Zero Dial	10
3.3	Calibration Switch (CAL).....	10
3.4	Balance Switch (B).....	10
3.5	Overrange LED (O/R)	10
3.6	Balance Potentiometer (B).....	10
3.7	Suppression Potentiometer (S).....	10
3.8	Gain Potentiometer (G).....	10
4.	CONTROLS - INTERNAL.....	11
4.1	Zero Switch (SW1).....	11
4.2	Gain Range Switch (SW5, sliders 1 - 6)	11
4.3	Quadrature Switch (SW5 slider 7)	11
4.4	Frequency Link (SP2)	11
4.5	Phase Switch (SW6).....	11
4.6	Lin/Unlin Link (SP4)	12
4.7	Suppression Switch (SW8, sliders 1 - 5).....	12
4.8	Filter Switch (SW8 slider 7).....	12
4.9	Output Mode Link (J1)	12
4.10	Channel Number Switch (SW3).....	12
4.11	Master/Slave Switch (SW5 slider 8).....	13
4.12	Scaling Switches (SW8 sliders 6 and 8)	13
5.	OUTPUT SCALING/635 DISPLAY	14
5.1	Selection of Amplifier Gain Range	14
6.	SETTING UP FACTORY-CALIBRATED LIN TRANSDUCERS	15
7.	SETTING UP UNCALIBRATED LIN TRANSDUCERS	15
8.	SETTING UP FACTORY-CALIBRATED PY TRANSDUCERS	16
9.	SETTING UP UNCALIBRATED PY TRANSDUCERS	17
10.	SPECIFICATION	20
11.	ISOLATED OUTPUT OPTION	21
12.	SAMPLE/HOLD OPTION	22

13. WARRANTY AND SERVICE23

Index of Figures

Fig. 1 Front Panel7
Fig. 2 Transducer connections to Back-plane.9
Fig. 3 Internal Controls Locations.....17

1. INTRODUCTION & ESSENTIAL READING

Sections 1 and (6 or 7 or 8 or 9 depending on your transducer) should be read as a minimum. Refer to other sections as required.

The 615 LIN Amplifier is a single-channel oscillator/demodulator providing constant current excitation and signal conditioning for half-bridge inductive transducers such as the RDP LIN and PY types. Refer also to the transducer manual, CD1019 for LIN transducers and CD1031 for PY transducers.

Calibrated Span and Zero dials and 6-way gain range switch allow easy setting up for 10v or 4-20mA outputs and additional output scaling controls allow the output to be displayed in engineering units consistent with optimum scaling of the integral linearisation circuitry when used with PY transducers.

The module is designed for use with the Modular 600 system and contains multiplexing circuits which allow excitation, unlinearised and scaled (linearised) output signals to be displayed via the 635 and 636 Monitor modules.

Other features include:

- a) Calibration check switch
- b) Overrange LED
- c) Quadrature signal control
- d) Excitation frequency selector
- e) Signal phase control
- f) Noise filter switch
- g) Master/slave switch
- h) High stability crystal oscillator (frequency and voltage)
- i) Front panel output jack
- j) Linearisation for PY transducers (may be linked out for LIN transducers)

SPECIAL NOTE: MASTER/SLAVE

1. If this module has been supplied in an RDP housing then it will have been configured as a master or slave as required. To avoid beat-frequency effects only one module per system is configured as a master to control excitation frequency of all other modules. In a system the master is generally the first module (channel 1), top rack of 605/6/7 systems.
2. If this module has been purchased on its own, it will be supplied as a master. If it is to be added to an existing system already fitted with one or more 615s, then it will need to be changed to a slave. See section 4.11.
3. If this unit is to be used on its own, that is with no other 615 module, it needs to be a master.

BLANK PAGE

1.1 Before Powering-up Check

1	The supply voltage is correct to suit the 631/632 unit fitted and input range selected
2	The various plug-in modules are in the correct positions in the housing.
3	The input and output plugs are in the correct sockets. Note that on the housing back-plane all input sockets and all output sockets are of the same type.
4	Before connecting a transducer, ensure that the correct excitation voltage has been set. <u>Too high a voltage can destroy a transducer</u>
5	That each module has a unique address. (see section 4.10)
6	The master/slave link is correctly set (see section 4.11)

NOTE: Ensure system is switched OFF when removing or replacing modules and ensure each module has unique address. Failure to do so may cause damage to modules.

1.2 Information on Conformity to EC Directives.

This module is not CE marked because it is intended for use as a component of a larger system. RDP CE mark full modular 600 systems that includes a 60X housing and a 63X power supply where the system is fully populated with either 600 series amplifier/display modules or blank panels.

If the module is part of a full 600 system, refer to the system manual (CD2010) for CE certification.

If the module is not part of the full 600 system, it is the responsibility of the organization / individual producing the system to assess and/or test EMC compatibility.

Fig.1 Front Panel

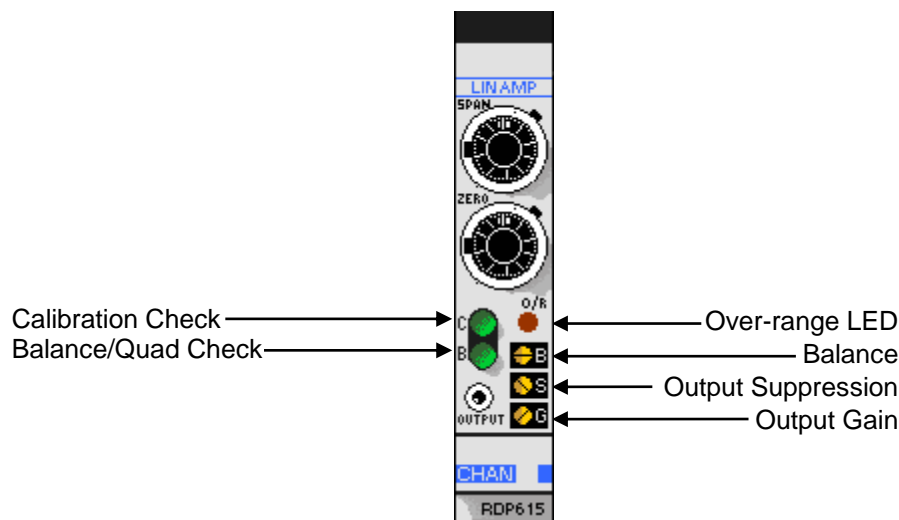

2. TRANSDUCER & OUTPUT CONNECTIONS

2.1 Transducer connections with 600 Backplane (Refer also to System Manual CD2010, Fig.6 etc.)

The backplane (external) connectors are arranged in columns of three. Each channel is identified with its number and each connector with a letter: A and B are for transducer inputs and C is the output connector.

When the 615 is used with the RDP backplane, transducer and output connections are made via circular DIN connectors as follows:-

Transducers: 7-pin Channel A (Connectors 1A to nnA) and, where two PY transducers are used: 7-pin Channel B (Connectors 1B to nnB):-

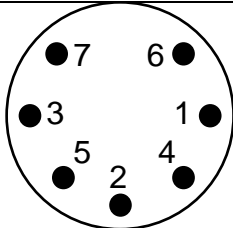
Transducer Connections See also fig. 2		
Connector viewed from rear.	PIN	FUNCTION
	1	Excitation
	2	Excitation
	3	Shield (screen)
	4	Signal centre tap (for single transducer systems)
	5	Signal centre tap (for double PY systems only)
	6,7	No connection

2.2 Output Connections with 600 backplane

Outputs: 5-pin connectors 1C to nnC :-

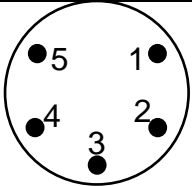
Output connections with 600 Backplane		
Connector viewed from rear.	PIN	FUNCTION
	1	Linearised/Scaled Output
	2	Output Common (0V)
	3	Unlinearised Output
	4	Isolated Output Common (Optional)
	5	No connection

Note Ground cable screen/shield either at transducer end or instrument end, **not** both, to avoid ground loop problems.

Transducers are normally grounded via metal clamps, etc. If not, then ground cable shield via pin 3 or for optimum EMC, via the connector body/cover (which is internally grounded)

2.3 OUTPUT CONNECTIONS VIA FRONT PANEL JACK PLUG

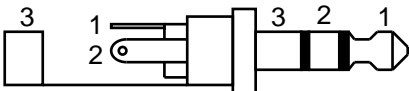
	PIN	FUNCTION
	1	Unlinearised Output
	2	Linearised/Scaled Output
	3	Output Common (0V)

2.4 Transducer & output connections using 32-way (DIN 41612) connector.
 (If using a 600 system housing, ignore section 2.4)

1	Excitation	Differential	Channel A (see note)
2	Excitation		
3	Screen (0V)		
4	Centre Tap 1 (Signal)		
5	Centre Tap 2 (Signal)		
6, 7	No connection		
8	Output (linearised or unlinearised)		
9	Output Common (0V)		
10	Output (unlinearised only)		
11	Excitation High	Channel B (see note)	
12	Excitation Low		
13	Screen (0V)		
14	Centre Tap 1 (Signal)		
15	Centre Tap 2 (Signal)		
16, 17	No connection		
18	Output (scaled)	Multiplexed for use with 635/6 only	
19	Output (unscaled)		
20	Excitation Output		
21	Master/Slave		
22	Output Hold		
23	Limits Reset/Isolated Output 0V		
24-27	Channel Address	Used with 635/6 only	
28	+5VD		
29	0VD		
30	+15V		
31	-15V		
32	0VA		

Note: Channels A and B are for applications using two single-coil PY transducers. Normally, only channel A is used, as standard PY transducers are double coil type.

Fig. 2 Transducer connections to Back-plane.

Note: MI cable sheath must be grounded. There are no connections to pins 6&7.

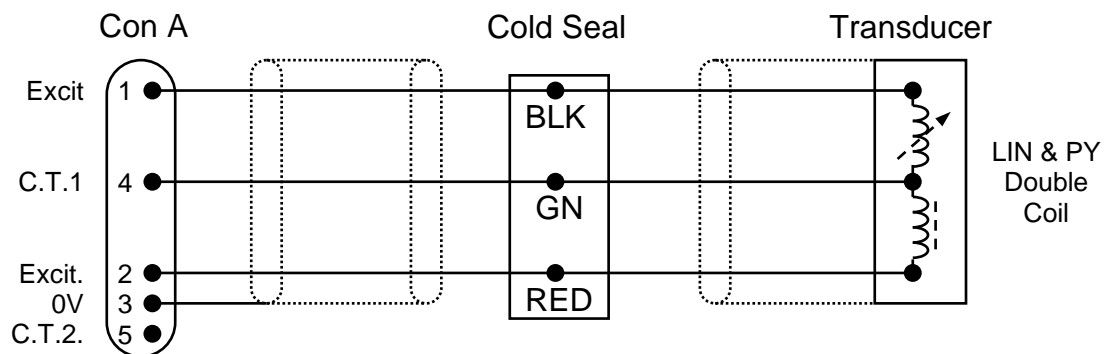

Active and comp connections may be reversed for some applications.

3. CONTROLS: FRONT PANEL

(Refer also to Fig.1)

3.1 Span Dial

This is a 10-turn calibrated control providing a 3:1 gain change to interpolate between the ranges of the Gain Range Switch; used in conjunction with the Zero dial to maintain the 0 to 10v signal input to the lineariser circuit (when using PY transducers).

3.2 Zero Dial

This is a 10-turn calibrated control providing an adjustment of amplifier input voltage to zero by balancing the transducer bridge circuit; used in conjunction with the Span dial to maintain the 0 to 10v signal input to the lineariser circuit.

3.3 Calibration Switch (CAL)

This is a momentary pushbutton switch which, when pressed, disconnects the transducer output from the amplifier input and reconnects the input to an internal reference.

3.4 Balance Switch (B)

This is a momentary pushbutton which, when pressed, disconnects the amplifier output from the synchronous demodulator and reconnects the output to a rectifier which allows the output to indicate out-of-phase or quadrature signals; used in conjunction with the Balance potentiometer.

3.5 Overrange LED (O/R)

This illuminates when the amplifier is operating outside its linear range, i.e. when a reduction in span or gain is required.

3.6 Balance Potentiometer (B)

This is a screwdriver-adjusted 20-turn control which may be used to cancel out excessive quadrature signals; used in conjunction with the Balance switch.

3.7 Suppression Potentiometer (S)

This is a screwdriver-adjusted 20-turn control which may be used with 4.7, the internal suppression switch, to offset the amplifier scaled output by up to $\pm 100\%$ (10v). This control does not affect the unlinearised output, lineariser 0 to 10v scaling or the 4-20mA output.

3.8 Gain Potentiometer (G)

This is a screwdriver-adjusted 20-turn control which provides a 3:1 adjustment of the scaled output which is displayed by the 635. When used with the internal Scaling switch, it allows the output to be scaled in engineering units, e.g. 6mm = 6v = 6.000 on the 635, etc.

This has no effect on the unlinearised output, the 0 to 10v input to the lineariser or the 4-20mA output.

4. CONTROLS - INTERNAL

Refer to Fig.3 for locations

4.1 Zero Switch (SW1)

This is a DIL, screwdriver-adjusted rotary switch that can be used to increase the range of the front panel zero dial in either direction, as shown:

Switch Function	Switch Position	
	Up to Mod 9K	Mod 10 Onwards
Increase Zero Range	1	2
Off	2	0 or 1
Increase Zero Range in Opposite Direction	3	3

4.2 Gain Range Switch (SW5, sliders 1 - 6) Refer also to Section 5.1.

Sliders 1 to 6 of this 8-way DIL switch, when used with the Span dial, allow a wide range of transducer signals to be scaled to 10v output, etc. as detailed below:

Switch Slider ON	Input Signal Range (V rms) for 10V Output
None	3 to 10
1	1 to 3
2	0.3 to 1
3	0.1 to 0.3
4	0.03 to 0.1
5	0.01 to 0.03
6	0.003 to 0.01

4.3 Quadrature Switch (SW5 slider 7)

Slider 7 of the Gain Range switch, when set to off, disconnects the Balance potentiometer from the amplifier circuit when this control is not required.

4.4 Frequency Link (SP2)

This solder pad is used to change the excitation frequency as follows:	Frequency kHz	Links Fitted
	2.4	B - C
	4.8	A - C and B - C
	9.6	D - C

4.5 Phase Switch (SW6)

This is an 8-way DIL switch which adjusts the phase of the demodulator synchronisation signal. This allows optimum amplitude/linearity to be obtained for LIN or PY transducers with long cables, etc. which may produce excessive phase shift in the transducer signal.

Levers 1 and 2 control the polarity of the demodulator output, i.e. 2 is normal, 1 inverts the phase/polarity. Levers 3 to 8 provide varying degrees of phase shift. Optimum setting of these may be determined by selecting that which produces the highest amplifier output with the transducer at full scale displacement. Normally, for LIN transducers with standard cable lengths, levers 1 + 4 are set to ON, and for PY types, 2 and 4 are set to ON.

Incorrect phase settings may be indicated by (a) apparently low transducer output signal, or (b) overrange lamp on with <10v output, etc. This may be checked by pressing the BAL (B) button and noting the change in output. If it increases significantly, e.g. by 50% or more, then the phase setting may be incorrect. In this case try setting sliders 3 through 8 on in turn. The optimum setting is indicated by pressing B producing little or no output change.

4.6 Lin/Unlin Link (SP4)

This allows the output signal to be derived from either the unlinearised transducer signal or the linearised transducer signal. When set to Unlin, the lineariser circuit is bypassed, e.g. when used with LIN transducers. When set to Lin, the lineariser circuit is included, e.g. for use with PY transducers. To summarise:

Link SP4 A-C for unlinearised output (LIN transducer)

Link SP4 B-C for linearised output. (PY transducer)

4.7 Suppression Switch (SW8, sliders 1 - 5)

Sliders 1 to 5 of 8-way DIL switch may be used with 3.7 to inject different amounts of zero suppression into the scaled output signal. For example, in order to obtain a unipolar output signal from a bipolar (LIN type) transducer, etc. the amplitude and polarity of the output shift varies with the slider settings as shown below. Note: the amount of shift will also depend on the setting of the Gain potentiometer. This control only affects the scaled output.	Slider ON	Approx. Output Shift (V)
	1	+2 to +7
	1 + 3	+4 to +10
	1 + 4	+6 to +10
	1 + 5	+8 to +10
	2	-2 to -7
	2 + 3	-4 to -10
	2 + 4	-6 to -10
	2 + 5	-8 to -10

4.8 Filter Switch (SW8 slider 7)

This may be set to ON to reduce amplifier output noise. The bandwidth is also reduced as detailed in the specification. The switch does not operate on the 4-20mA output signal.

4.9 Output Mode Link (J1)

This is a 4-way jumper link which provides the following output modes:

Link Setting	Output Mode
B – C	Voltage ($\pm 10V$) (scaled)
D – C	Current (4-20mA)
A – C	Sample/Hold Output (Option)
E – C	Isolated Output (Option)

4.10 Channel Number Switch (SW3)

Refer also to CD2004 (635/636 manual, if units are fitted)

This is a 16-way (hexadecimal) screwdriver-adjusted rotary switch scaled 0 - 9 and A - F. When a 615 is used with a backplane, the correct channel address number must be set on this switch.

Each channel must have a different number set to avoid output signal contention on the backplane A, B and EX signal busses which are monitored by the 635 or 636. **Failure to do so may cause damage to modules.**

Channels 1 to 15 settings are as shown below:

Card No.	1	2	3	4	5	6	7	8	9	10	11	12	13	14	15
Switch Position.	1	2	3	4	5	6	7	8	9	A	B	C	D	E	F

4.11 Master/Slave Switch (SW5 slider 8)

The position of this lever determines whether a module is configured as a master oscillator or slave unit. Normally, in multi-channel systems, channel 1 is designated as master with all other channels deriving their excitation frequency (and amplitude) from this channel.

For master or stand-alone module, set slider 8 to ON. For slave modules, set slider 8 to OFF.

If output "beating" is still apparent, then on the slave module remove all SP2 solder links and fit SP5 solder link (on rear of the circuit board).

4.12 Scaling Switches (SW8 sliders 6 and 8)

Slider 6, when set to OFF, inverts the amplifier scaled output signal, e.g. if a PY gap change of 3 to 0mm is to be displayed as 0 to +3.000 etc.

Slider 8, when set to OFF, reduces the scaled output voltage by approximately one-third which allows further display scaling.

Neither of these controls affects the unlinearised output, the 0 to 10v scaling of the lineariser circuit or the 4-20mA output.

5. OUTPUT SCALING/635 DISPLAY

The 615 produces two outputs: (a) unlinearised and (b) linearised/scaled. When used with PY transducers the unlinearised output must always be scaled 0 to 10v for zero to full gap for the linearisation circuit to function correctly. This is achieved via the SPAN and ZERO dials which are adjusted to compensate for transducer temperature changes etc. to retain this scaling at all times.

To scale the output or 635 display in engineering units, the suppression (S) and Gain (G) controls are used, usually to scale down or offset the output signal, e.g. this allows a PY156 displacement of between 1mm and 3mm to be scaled to a 0v to 2v output (0000 to 2.000 display) without affecting the lineariser 0 to 10v scaling.

Both outputs are available at:

- (a) the backplane output connector
- (b) the front panel jack
- (c) the backplane A and B signal busses connected to the 635.

Selecting B on the 635 monitors the unlinearised output (0 to 10v = 000 to 10.000 display); selecting A monitors the scaled/linearised output.

5.1 Selection of Amplifier Gain Range

(for $\pm 10v$ output with LIN transducers and 0 to 10v output with PY transducers)

Transducer Type	Approximate FS Signal (mV)	Gain Slider ON for Output of:	
		0-10V or 4-20mA	$\pm 10V$
LIN52	± 460	1 or 2	2
LIN56	± 110	3	3
LIN152	± 1500	None or 1	1
LIN156	± 400	2	2
LIN252	± 2500	None	1
LIN256	± 630	1	2
PY102C	40	4	
PY106C	15	5	
PY152C	150	3	
PY156C	75	4	
PY252C	300	2 or 3	
PY256C	550	2	

6. SETTING UP FACTORY-CALIBRATED LIN TRANSDUCERS

(Refer also to Transducer Manual CD1019)

- 6.1 Connect the transducer as detailed in Section 2.
- 6.2 Check SPAN and ZERO dials are set as indicated on the calibration certificate provided with the system.
- 6.3 Switch on power and check amplifier output is proportional to stroke. Note that removing the armature from the transducer gives a zero output from the transducer, and should give a 0V/12mA output from the amplifier/635 display etc.
- 6.4 Check, on pressing the CAL switch, that output is as indicated on the certificate.

7. SETTING UP UNCALIBRATED LIN TRANSDUCERS

(Refer also to Transducer Calibration Certificate & Manual CD1019)

- 7.1 Set the internal controls as follows: (Refer to Fig.3 for locations)
 - (a) Initially set all DIL switch (SW5, 6, 8) sliders to OFF.
 - (b) ZERO switch (SW1) to OFF. (With screwdriver). See Section 4.1.
 - (c) PHASE switch (SW6) sliders 1 and 3 to ON. (Or 1 + 4. See Section 4.5).
 - (d) LIN/UNLIN solder link (SP4) to A-C (unlinearised) (With soldering iron).
 - (e) Set SW5 (gain) slider 8 to ON for master or stand-alone oscillator.
 - (f) Set SW8 (suppression) sliders 6 AND 8 to ON for normal output polarity AND scaling.
 - (g) Set SW3 (channel No switch) as in Section 4.10 (if using RDP back plane).

UNSCALED output is monitored from	1) Channel B of the 635/636/650 unit (if fitted) and 2) Between pins 2&3 of back plane output C (if fitted) and 3) See sect. 2.3 if using the front panel jack plug.
SCALED output is monitored from	1) Channel A of the 635/636/650 unit (if fitted) and 2) Between pins 1&2 of back plane output C (if fitted) and 3) See sect. 2.3 if using the front panel jack plug.

- 7.2 Determine the transducer output from Section 5.1 (for RDP transducer outputs) and set the Gain Range switch as shown in Section 4.2 and Section 5.1.
- 7.3 Connect the transducer as detailed in Section 2. Switch ON power and allow a 15-minute warm up period (for maximum accuracy).
- 7.4 Remove the armature from the transducer and adjust the ZERO dial for zero output.
- 7.5 Replace the armature in the transducer and adjust the armature for zero output. The ZERO control may be used to obtain an absolute zero indication if the armature adjustment is too coarse. This determines the transducer centre-stroke position.

Now proceed with either 7.6 or 7.7 according to application.

7.6 Half-Stroke Operation (Bipolar Output)

- (a) Move the transducer armature by a precise amount (e.g. 15mm for a LIN156 etc) and adjust the SPAN control for the desired output, e.g. 10v. Adjust phase switch if necessary (See Section 4.5).

- (b) Relocate the transducer armature at the centre of the stroke and check that the output is zero. Re-adjust the ZERO control if necessary.

Repeat (a) and (b) for consistent results.

- (c) Move the armature to the full-scale position in the opposite direction and check for -10v output.
- (d) Operate the CAL switch to obtain an output value which may be recorded for future checks on amplifier stability, etc.

7.7 Full Stroke Operation (Unipolar Output) (Continued from section 7.5)

If it is required that the transducer be used over its entire working range in one direction, e.g. 0 to 30mm for a LIN transducer, then the suppression controls are used to "back off" the signal equivalent to 15mm.

- (a) Move the armature to the full scale output position (e.g. 15mm etc.) and adjust SPAN for +5v (or 12mA output). Adjust phase switch if necessary. (See Section 4.5)
- (b) Use the suppression controls to change this to +10v (or 20mA). (See sections 3.7 & 4.7)
- (c) Move the armature to the zero output position (e.g. -15mm etc.) and check for 0v (or 4mA) output.
- (d) Operate the CAL switch as in 7.6(d).

NOTE: the unscaled output (B on the 635) will be $\pm 5v$ bipolar.

8. SETTING UP FACTORY-CALIBRATED PY TRANSDUCERS (Refer also to Transducer Manual CD1031)

- 8.1 Connect the transducer as detailed in Section 2.
- 8.2 Check SPAN and ZERO dials are set as indicated on the calibration certificate provided with the system.
- 8.3 Switch on power and check amplifier output is proportional to transducer target gap (normally zero gap = 0v/4mA output, full scale gap = 10v/20mA).

Note that any metal in close proximity to the transducer, e.g. clamp, etc. or different target shape, cable length, etc. may slightly alter the zero and sensitivity. This may be compensated by small adjustments to the SPAN and ZERO dials.

For systems where these settings are specified at various transducer temperatures, then the difference in the above settings must be applied at all temperatures, e.g.

If a room temperature ZERO setting of 5.65 is specified but a setting of 5.55 is required to suit the application, then all other ZERO settings must be reduced by the same amount, ie. 0.10.

The same applies to SPAN settings.

- 8.4 Press the CAL switch and check output is as indicated on the certificate. Note: this output may vary slightly with gap.

9. SETTING UP UNCALIBRATED PY TRANSDUCERS

(Refer also to Transducer Calibration Certificate & Manual CD1031)

Fig. 3 Internal Controls Locations

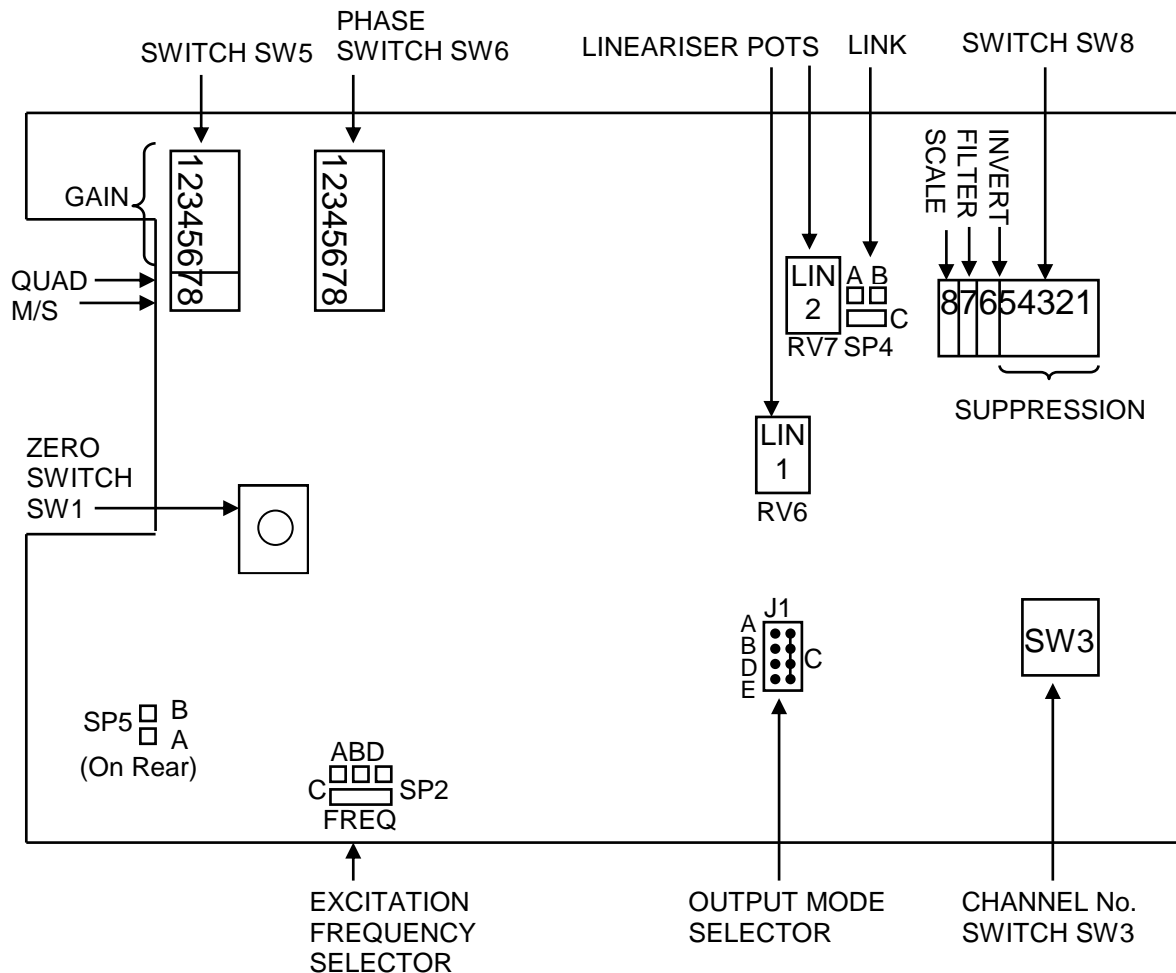

9.1 Set the internal controls as follows: (Refer to Fig. 3 for locations)

- Initially set all DIL switch (SW5, 6, 8) sliders to OFF
- ZERO – switch SW to OFF (with screwdriver). See Section 4.1.
- QUAD – (GAIN SW5 slider 7) to ON
- PHASE – switch SW6 sliders 2 + 4 ON.
- LIN/UNLIN – link SP4 to B-C (linearised) (with soldering iron)
- Set SW5 (gain) slider 8 to ON for master or stand-alone oscillator
- Set SW8 (suppression) sliders 6 and 8 to ON for normal output polarity and scaling.
- Set channel No. switch (SW3) as in section 4.10 (if using RDP back-plane)

UNLINEARISED output is monitored from	1) Channel B of the 635/636/650 unit (if fitted) and 2) Between pins 2&3 of back plane output C (if fitted) and 3) See sect. 2.3 if using the front panel jack plug.
LINEARISED output is monitored from	1) Channel A of the 635/636/650 unit (if fitted) and 2) Between pins 1&2 of back plane output C (if fitted) and 3) See sect. 2.3 if using the front panel jack plug.

9.2 Determine the transducer output from the manufacturer's data sheet (or refer to Section 5.1) and set the GAIN RANGE (SW5) switch as shown in Section 4.2 and Section 5.1.

9.3 Connect the transducer as shown in Section 2. Fit the 615 into the rack via an extender board as adjustments are necessary to some internal controls. Switch on power and allow a 15-minute warm up period for maximum accuracy.

Configuring the UNLINEARISED output.	
	Monitoring <u>UNLINEARISED</u> output, perform the following
9.4	Set the transducer target gap to zero (0mm). Press and hold the BAL switch (marked 'B' in front panel) 1) Adjust the ZERO control (front panel) to obtain the minimum reading. 2) Adjust the BAL control (marked 'B' on front panel) to obtain a minimum reading, or a reading as low as possible 3) Repeat step 1, Repeat step 2. Release BAL switch.
9.5	Readjust ZERO for 0v/4mA output.
9.6	Set the gap to full scale for the transducer, and adjust the SPAN (front panel) control for 10v/20mA. ONLY IF THIS IS NOT POSSIBLE see Notes 1 and 2 and adjust phase switch if necessary. (See Section 4.5).
9.7	Re-check zero and full scale outputs.
	(The module is now set up in unlinearised mode, you may lock the zero and gain dials.

Configuring the LINEARISED output.	
	Monitoring <u>LINEARISED</u> output, perform the following
9.8	Adjust the transducer for zero gap and adjust the 'S' control (front panel) for 0V/4mA Adjust the transducer for full scale gap and adjust the 'G' control (front panel) for 10V/20mA output. Re-check both zero and full scale points.
9.9	Set the gap to half F.S. and adjust "LIN.1" (RV6) for 5v output. (see Fig. 3)
9.10	Set the gap to 3/4 F.S. and adjust potentiometer "LIN.2" (RV7) for 7.5v output. Recheck zero and full scale positions.
9.11	If desired, the Fine Gain "G" control may be adjusted for the 635 display to indicate directly in mm, e.g. 6.000 F.S. for a PY256, etc. also, the suppression controls "S" and SW8 may be used to provide, say, a 0 to 3.000mm display for an actual gap change between 1 & 4mm, etc.
	The 615 LINEARISED output is now set up.

	MONITORING O/P	PERFORM THE FOLLOWING
9.12	UNLINEARISED	Set the gap to Full Scale, press the CAL button (front panel) and note the reading in pencil here Unlinearised output cal reading = _____
9.13	LINEARISED	Set the gap to Full Scale, press the CAL button (front panel) and note the reading in pencil here Linearsied output cal reading = _____

Note 1 For the lineariser circuitry to function correctly, the unlinearised output must range between 0v and +10v for 0 to F.S. gap. The unlinearised output may be monitored by selecting "Signal B" on the 635/636 monitor or via the front panel jack.

Unless specified otherwise, the relationship between unlinearised and scaled linearised output is factory set to 1:1, i.e. 0 to 10v unlinearised = 0 to 10v scaled = 4 to 20mA.

Note 2 When the lineariser circuit is used with PY transducers, the very high gain produced at or near full scale output means that the amplifier output ripple may be higher than that specified. If this is a problem, then it may be reduced by (a) operating the filter switch (reducing bandwidth), or (b) increasing excitation frequency

10. SPECIFICATION

Supply:	$\pm 15\text{V}$ ($\pm 1\text{V}$) unregulated for V output. 1% regulation for 4-20mA output. $\pm 60\text{mA}$ typical (normally derived from 631/632 power supplies).
Excitation:	Constant current differential 10mA ($\pm 1\text{mA}$) at 2.4/4.8/9.6kHz sinusoidal, at 17V rms maximum. Crystal controlled (standard is 4.8).
Stability:	Of frequency: 100ppm typical Of amplitude: 30ppm typical
Regulation:	0.2% per 100 ohm load change typical
Distortion:	1% t.h.d typical
Amplifier:	Synchronous demodulator with analogue multiplier lineariser
Signal Range:	10mV to 10V rms in 7 ranges for 10V or 16mA output change
Input Impedance:	1M ohm
Bandwidth:	200Hz flat unlinearised 160Hz flat linearised (20Hz with filter ON)
Output:	$\pm 10\text{V}$ at 5mA or 4-20mA into 0-450 ohm. This is an active output that must not be connected to any external power supply as this will damage unit.
Ripple:	3mV/50 μA unlinearised p-p 10mV/120 μA linearised (4mV with filter ON) p-p typical
Linearity:	$\pm 0.05\%$ typical for amplifier only $\pm 1\%$ or better with PY transducers
Tempco. Zero:	0.005%/°C typical
Tempco. Gain:	0.005%/°C typical (0.02%/°C for linearised outputs). Optimum at $\pm 10\text{V}$ output.
General: Supply:	$\pm 15\text{V}$ ($\pm 0.5\text{V}$) dc at 70mA typical
Dimensions:	PCB 160 x 100 x 15mm (Eurocard). Overall length 198mm (including controls)
Front Panel:	128(3U) x 25mm (5 x 1 inches)
Operating Temp. Range:	0 to 60°C

11. ISOLATED OUTPUT OPTION

This is an add-on pcb which galvanically isolates the amplifier output signal from the rest of the system.

Output signal connections are detailed in Section 2, i.e. output signal on pin 1 of the 5-pin backplane connector C, as normal, but the output common signal is now at pin 4 with pin 2 not used.

Option boards are normally supplied set for $\pm 10\text{v}$ output signals. To use the 4-20mA output, change SP1 and 2 on the option board to B-C. No change is required to the main pcb.

If the option board is to be retro-fitted to an existing 615, then to change the output from normal to isolated, change link J1 to EC.

The option board has unity gain (fixed) for voltage outputs so that setting-up procedure is as for normal units. Single-turn potentiometers provide a small adjustment of offset and gain for the 4-20mA outputs as follows:

RV1 set 4mA (\equiv zero display on 635/6)

RV2 set 20mA (\equiv 10.000 display on 635/6)

Note: these are normally factory-set so that the normal output to 4-20mA output relationship is:

+10v normal = 20mA

0v normal = 4mA.

Specification

As for 615 with the following amendments and additions:

Output, current mode:	4-20mA into 0 to 400 ohm
Isolation Voltage:	500V dc
Isolation Resistance:	500M ohm
Output Noise:	Has an additional high frequency component (spikes) of typically 20mV rms which could generally be disregarded
Gain (of extra Isolation Amplifier)	1 : 1 $\pm 0.05\%$ typical

12. SAMPLE/HOLD OPTION

This provides a fast, analogue sampling or hold of the 615 output signal. An external TTL signal is applied to the hold input as follows:

Hold Signal High (or open circuit) :	Normal operation – output follows transducer signal.
Hold Signal Low :	HOLD mode – output holds the value extant at the moment of application. Output droops as detailed in the specification.

Note 1

With no connection to the hold line, internal pull-up resistors allow the amplifiers to operate normally.

Note 2

TTL signal is referred to 0VD pin 29.

For sample/hold operation link J1 must be set to A-C.

Connections

The hold signal is connected via the 8-pin connector on the rear panel of the rack housing (604 etc.). Pin 1 is hold signal and pin 3 is 0v (common).

Specification

Response Speed :	20 μ seconds typical
Output Droop :	<2mV (0.01% FS) per second typical
Hold Step Error :	<0.1% FS typical
TTL Load :	10 μ A max. plus 47k pull-up per board

13. WARRANTY AND SERVICE

WARRANTY.

R.D.P. Electronics products are warranted against defects in materials or workmanship. This warranty applies for one year from the date of delivery. We will repair or replace products that prove to be defective during the warranty period provided they are returned to R.D.P. Electronics.

This warranty is in lieu of all other warranties, expressed or implied, including the implied warranty of fitness for a particular purpose to the original purchaser or to any other person. R.D.P. Electronics shall not be liable for consequential damages of any kind.

If the instrument is to be returned to R.D.P. Electronics for repair under warranty, it is essential that the type and serial number be quoted, together with full details of any fault.

SERVICE.

We maintain comprehensive after-sales facilities and the instrument can, if necessary be returned to our factory for servicing.

Equipment returned to us for servicing, other than under warranty, must be accompanied by an official order as all repairs and investigations are subject to at least the minimum charge prevailing at the date of return.

The type and serial number of the instrument should always be quoted, together with full details of any fault and services required.

IMPORTANT NOTES.

1. No service work should be undertaken by the customer while the unit is under warranty except with the authorisation of RDP Electronics.
2. If the instrument is to be returned to R.D.P. Electronics for repair, (including repair under warranty) it is essential that it is suitably packed and that carriage is insured and prepaid. R.D.P. Electronics can accept no liability whatsoever for damage sustained during transit.
3. It is regretted that the above warranty only covers repairs carried out at our factory. Should the instrument have been incorporated into other equipment that requires our engineers to perform the repair on site, a charge will be made for the engineer's time to and from the site, plus any expenses incurred.

The aforementioned provisions do not extend the original warranty period of any product that has been either repaired or replaced by R.D.P. Electronics.

**THIS WARRANTY MAY BE NULL AND VOID SHOULD
THE CUSTOMER FAIL TO MEET OUR TERMS OF PAYMENT.**